

Data Sheet

Pressure control valve
Type **KDC 65-200**

Efficient control of excessive discharge pressure



The KDC valve is a pressure control valve. The valve controls the discharge pressure of the compressor to ensure fast build-up of pressure and lubrication pressure. The valve also acts as a check valve in the discharge line of the compressor.

The KDC valve is force-controlled so that when pressure in the oil separator becomes 2 bar (29 psi) higher than the suction pressure, the spring is compressed and the valve opens. In low pressure units (boosters), the spring requires a differential pressure of 0.5 bar (7 psi) for the valve to open.

Features

- Applicable to HCFC, HFC, R717 (Ammonia) and R744 (CO₂).
- Each valve type is clearly marked with type, size and performance range
- Angle valves with weld connections
- Fast build-up of oil pressure in oil separator during start-up.
- High closing force on the cone during standstill, even without differential pressure across the valve
- Very low pressure drop because of spring force
- Low part-load without risk of valve chattering
- Stainless steel bolts
- Housing and bonnet material is in low temperature steel according to requirements of the Pressure Equipment Directive and other international classification authorities
- Pressure range: 40 bar (580 psig)
- Temperature range: -50 °C / +150 °C (-58 °F / +302 °F)
- Classification: DNV, CRN, BV, EAC etc. To get an updated list of certification on the products please contact your local Danfoss Sales Company.

Functions

The KDC valve opens in a 3 step sequence. The sequence of steps depends on the start-up situation (see [Figure 1: KDC valve](#)).

Step 1

The valve is always closed by a minimum differential pressure of 1.5 to 2.0 bar (0.3 to 0.5 bar in a booster system). Step 1 will occur when the compressor is stopped and the discharge pressure has equalized to the top of the valve through the suction side of the compressor.

$$p_c - p_1 < 2 \text{ bar (0.5 bar for booster) and } p_c > p_2$$

Step 2

Step 2 will occur as soon as the condensing pressure becomes higher than the pressure in the oil separator, and when the differential pressure between suction side and condensing pressure is bigger than the spring force.

$$p_c - p_1 > 2 \text{ bar (0.5 bar for booster) and } p_c > p_2$$

When the compressor starts the valve will either be in step 1 or step 2 position, depending on the pressure difference between the oil separator and the condensing pressure.

Start up situation 1

Condensing pressure is lower than oil separator pressure.

Start up will occur from step 1 position and go to step 3 as soon as a differential pressure between suction side and oil separator that can overcome the spring force is present.

Start up situation 2

Condensing pressure is higher than oil separator pressure but the differential pressure is lower than the spring force.

Start up will occur from step 1 and go to step 2 when differential pressure between suction side and condensing pressure is bigger than the spring force. When oil separator pressure comes close to the condensing pressure the valve will start opening and the small spring will open the valve completely. The valve will then be in step 3 position.

Start up situation 3

Condensing pressure is higher than oil separator pressure + spring force pressure. Start up will occur from step 2 position.

When oil separator pressure comes close to the condensing pressure the valve will start opening and the small spring will open the valve completely. The valve will then be in step 3 position.

When the compressor stops, the valve will be in step 3 position and as soon as the condensing pressure has equalized to the suction side the spring force will close the valve. The valve will be in step 1 position until enough differential pressure between condensing pressure and oil separator/suction side pressure occurs for the valve to enter into step 2 position.

i NOTE:

The KDC valve cannot be used on compressor units where the non-return valve is placed between compressor and oil separator instead of on the suction side of the compressor. The reason for this is that the KDC valve needs to have the pilot pipe connected to a point on the compressor unit, where the pressure is low during running and high during standstill.

Pressure control valve, type KDC 65-200

Figure 1: KDC valve

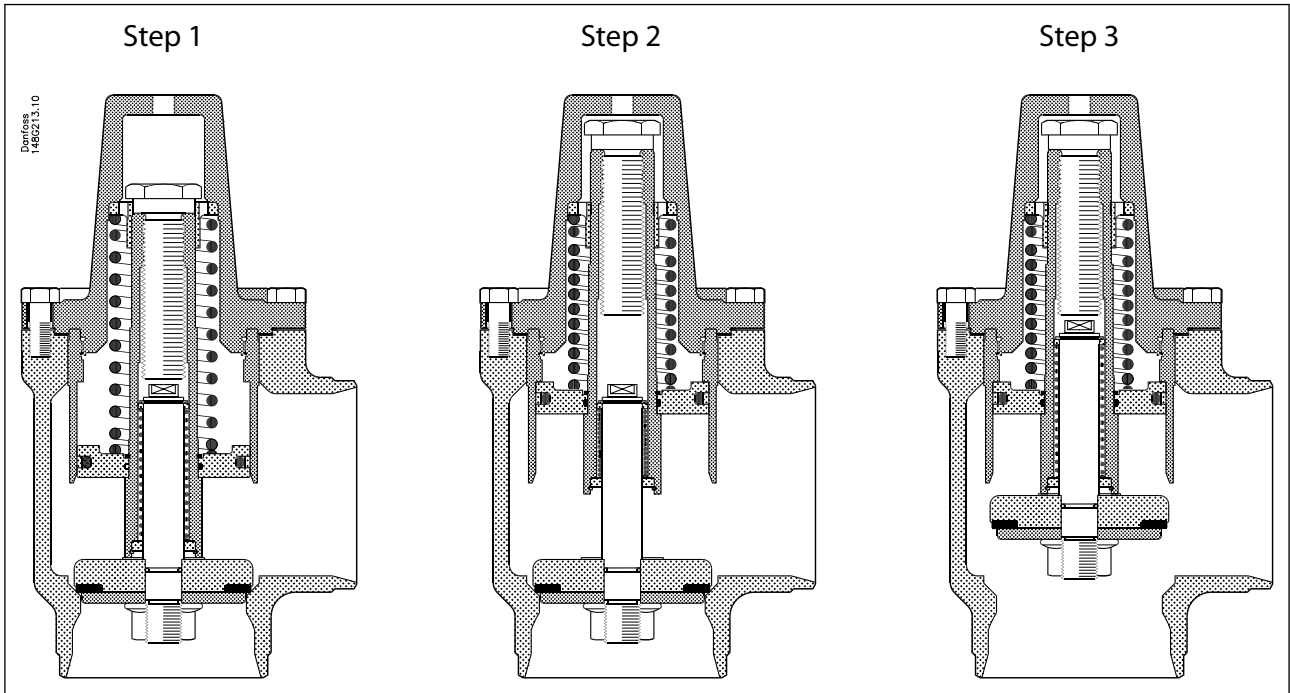
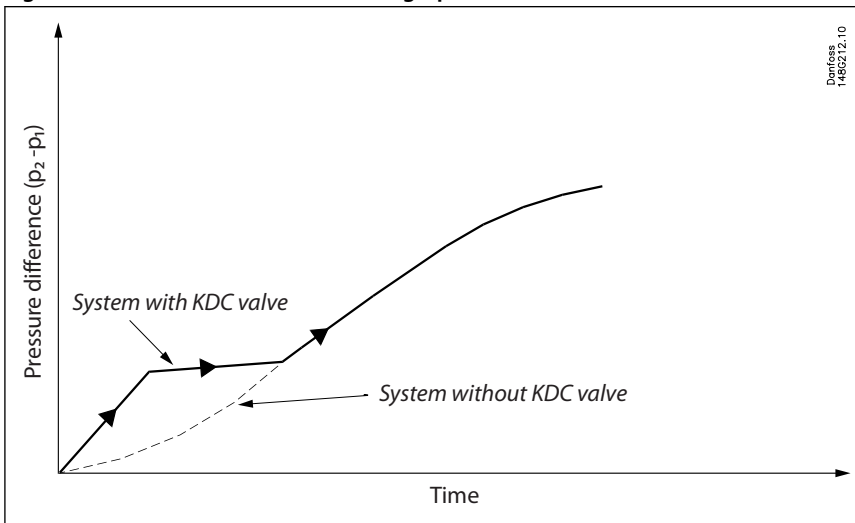

Figure 2: Time and Pressure difference graph



Applications

Example

Figure 3: Compressor discharge line after oil separator

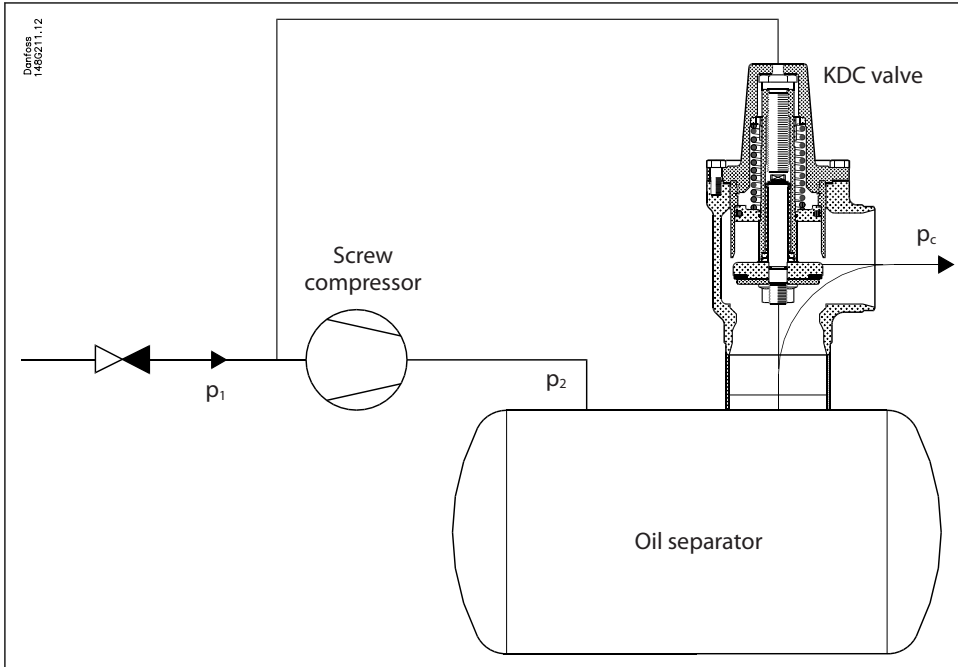

Media

Refrigerants

Applicable to HCFC, HFC, R717(Ammonia) and R744 (CO₂).

For further information please see installation instruction for KDC.

New refrigerants

Danfoss products are continually evaluated for use with new refrigerants depending on market requirements.

When a refrigerant is approved for use by Danfoss, it is added to the relevant portfolio, and the R number of the refrigerant (e.g. R513A) will be added to the technical data of the code number. Therefore, products for specific refrigerants are best checked at store.danfoss.com/en/, or by contacting your local Danfoss representative.

Product specification

Pressure and temperature

Table 1: Pressure and temperature

Description	Values
Temperature range	-50 °C / +150 °C (-58 °F / +302 °F)
Pressure range The valves are designed for max. working pressure	40 bar (580 psig)

Design

Housing

Made of special, cold resistant steel approved for low temperature operations.

Valve cone

The valve cone has two teflon tightening rings with built-in metallic stops to prevent damage to the teflon rings in case of an extreme pressure difference.

Spindle

The spindle is made of gas-tempered steel. Consequently the valve spindle has an extremely hard and smooth surface. The valve rod has an internal weak spring (Figure 4: KDC, pos. 13), which is active when the servo piston is in upright position.

Actuator

The KDC actuator has one chamber. It is separated from the main flow by a piston (Figure 4: KDC, pos. 6). The chamber has a spring (Figure 4: KDC, pos. 14) which provides differential opening of the valve. The chamber of the actuator is connected to the suction line of the compressor.

Installation

The valve must be mounted vertically with the cone in downward position. On top of the bonnet the actuator has one threaded (NPT 1/4 in.) connection (Figure 4: KDC, pos. A) for the pilot line. Fittings for connection of steel pipe DN 10 (do/di = 10/6 mm) by means of cutting rings. The valve is designed to resist very high internal pressure, but as to the pipe system in general, hydraulic pressure caused by thermal expansions in entrapped refrigerants should be avoided.

For further information please refer to KDC installation instruction.

Pressure control valve, type KDC 65-200

Figure 4: KDC

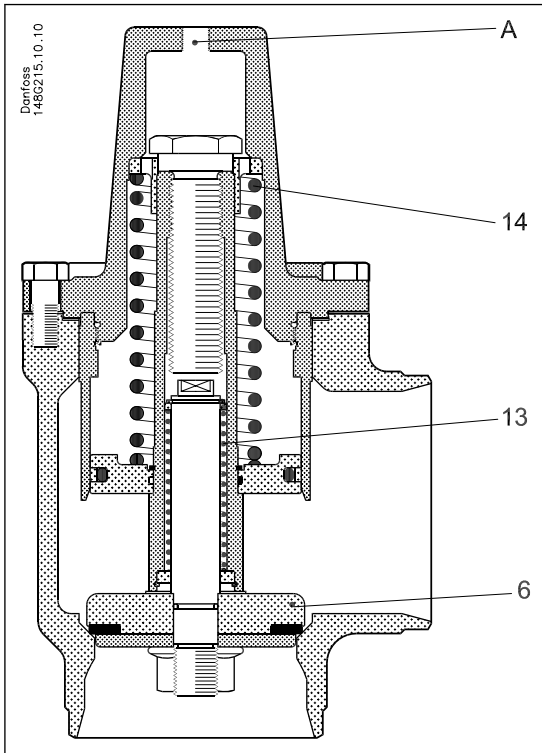
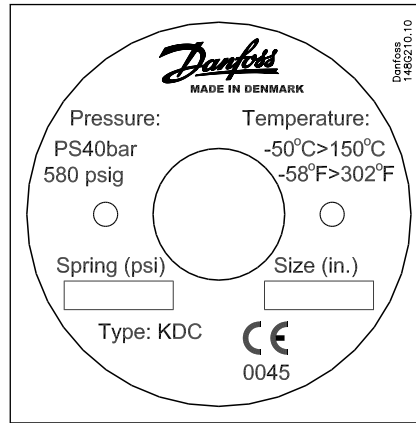

Figure 5: Example of ID-plate for KDC



Connections

Available with the following connections:

- Butt-weld DIN (2448)
- Butt-weld ANSI (B 36.10 Schedule 40), DN 65 - 200 (2½ - 8 in.)

Figure 6: DIN

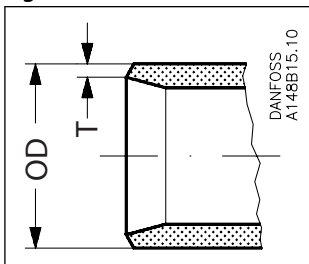

Table 2: Butt-weld DIN (2448)

Size mm	Size in.	OD mm	T mm	OD in.	T in.	k _v -angle m ³ /h	C _v -angle USgal/min
65	2½	76.1	2.9	3	0.11	78	90
80	3	88.9	3.2	3.50	0.13	118	137
100	4	114.3	3.6	4.50	0.14	203	235
125	5	139.7	4.0	5.50	0.16	333	386
150	6	168.3	4.5	6.63	0.18	509	590
200	8	219.1	6.3	8.63	0.25	757	878

Figure 7: ANSI

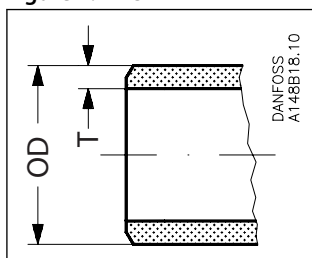

Table 3: Butt-weld DIN (2448)

Size mm	Size in.	OD mm	T mm	OD in.	T in.	k _v -angle m ³ /h	C _v -angle USgal/min
65	2½	73.0	5.2	2.87	0.20	78	90
80	3	88.9	5.5	3.50	0.22	118	137
100	4	114.3	6.0	4.50	0.24	203	235
125	5	141.3	6.6	5.56	0.26	333	386
150	6	168.3	7.1	6.63	0.28	509	590
200	8	219.1	8.2	8.63	0.32	757	878

Nominal capacities

High pressure compressor

Capacity table at $t_c / t_o = +35\text{ °C} / -15\text{ °C}$,

Q_N [kW],

$\Delta p = 0.05\text{ bar}$

Table 4: Capacity table

	KDC 65	KDC 80	KDC 100	KDC 125	KDC 150	KDC 200
R717	434	656	1128	1851	2829	4207
R404A	132	200	344	564	863	1283
R22	157	238	410	672	1028	1528

Booster compressor

Capacity table at $t_c / t_o = -18\text{ °C} / -40\text{ °C}$,

Q_N [kW],

$\Delta p = 0.05\text{ bar}$

Table 5: Capacity table

	KDC 65	KDC 80	KDC 100	KDC 125	KDC 150	KDC 200
R717	229	347	597	978	1496	2225
R404A	101	153	263	432	661	983
R22	102	154	265	435	665	990

Material specification

Figure 8: KDC 65 - 200 (2½ - 8 in.)

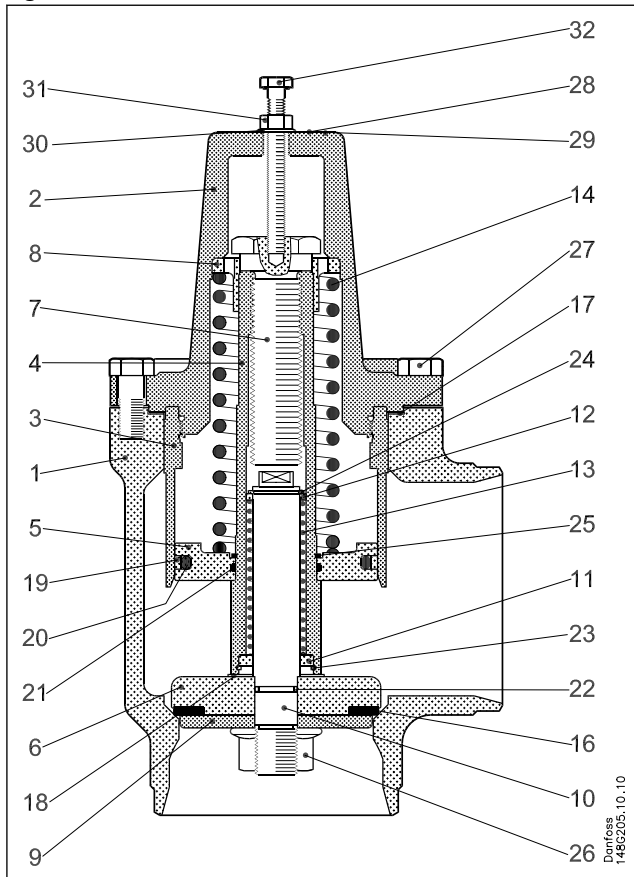

Table 6: Material and Parts list

No.	Part	Material	EN	ISO	ASTM
1	Valve House	Steel	G20Mn5QT EN10213-3		LCC A352
2	Bonnet	Steel	P285QH EN10222-4		LF2 A350
3	Piston	Steel	S235JRG2 EN10025	Fe260B 630	Grade C A283
4	Piston rod	Steel	S235JRG2 EN10025	Fe260B 630	Grade C A283
5	Piston	Steel	11SMn30 EN10087	Type 2 R683/9	Grade 1213 A29
6	Cone	Steel	11SMn30 EN10087	Type 2 R683/9	Grade 1213 A29
7	Screw for spring	Steel	11SMn30 EN10087	Type 2 R683/9	Grade 1213 A29
8	Bushing for spring	Cast iron			
9	Cone plate	Steel	11SMn30 EN10087	Type 2 R683/9	Grade 1213 A29
10	Cone rod	Steel	11SMn30 EN10087	Type 2 R683/9	Grade 1213 A29
11	Rear bushing	Cast iron			
12	Front bushing	Cast iron			
13	Spring for cone	Steel			
14	Spring	Steel			
16	Teflon ring	PTFE			
17	Gasket	Fiber gasket non-asbestos			
18	Washer	Nylon			
19	Glide ring	PTFE			

Pressure control valve, type KDC 65-200

No.	Part	Material	EN	ISO	ASTM
20	O-ring	Cloroprene (Neoprene) (Standard KDC)			
		FKM (Hydrocarbon KDC)			
21	O-ring	Cloroprene (Neoprene) (Standard KDC)			
		FKM (Hydrocarbon KDC)			
22	O-ring	Cloroprene (Neoprene) (Standard KDC)			
		FKM (Hydrocarbon KDC)			
23	Retaining ring bore	Steel			
24	Spring ring	Steel			
25	Spring ring	Steel			
26	Nut	Steel			
27	Bolts	Steel	A2-70 EN1515-1	A2-70 3506	Grade B8 A320
28	ID plate	Aluminium			
29	Driv screw	Steel			
30	Washer	Steel			
31	Nut	Steel			
32	Screw	Steel			

Dimensions and weights

Figure 9: KDC 65 - 200 (2½ - 8 in.)

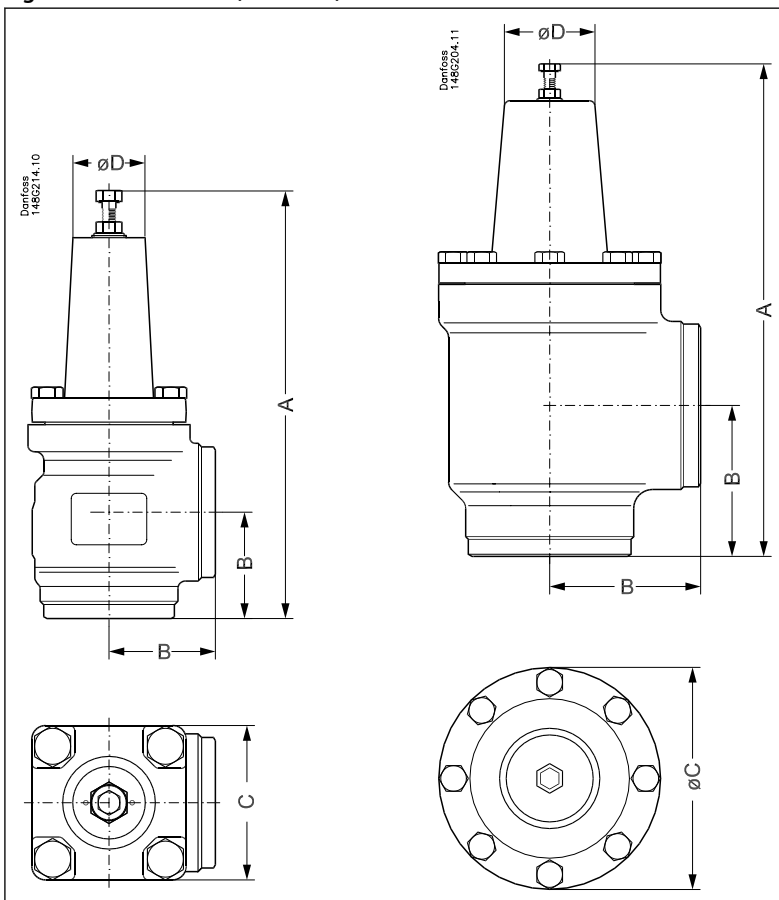

Pressure control valve, type KDC 65-200

Table 7: KDC types

Valve size		A	B	C	ØD	Weight
KDC 65	mm	250	62	90	42	7.3 kg
KDC 2½	in.	9.84	2.44	3.54	1.65	16.1 lb
KDC 80	mm	298	90	129	51	11.1 kg
KDC 3	in.	11.73	3.54	5.08	2.01	24.5 lb
KDC 100	mm	346	106	156	64	17.3 kg
KDC 4	in.	13.62	4.17	6.14	2.52	38.1 lb
KDC 125	mm	407	128	192	64	36.9 kg
KDC 5	in.	16.02	5.04	7.56	2.52	81.3 lb
KDC 150	mm	471	145	219	75	49.9 kg
KDC 6	in.	18.54	5.71	8.62	2.95	110.0 lb
KDC 200	mm	539	180	276	75	99.6 kg
KDC 8	in.	21.22	7.09	10.87	2.95	219.6 lb

NOTE:

Specified weights are approximate values only.

Bolt in top of the valve is for transportation purposes only. For further information please see installation instruction.

Ordering

IMPORTANT:

Where products need to be certified according to specific certification societies or where higher pressures are required, the relevant information should be included at the time of ordering.

Table 8: Standard KDC with welding branches - DIN

Size		Type	bar	Code no.
mm	in.			
65	2½	KDC 65	0.5	148G3585
			2	148G3586
			3	148G3713
80	3	KDC 80	0.5	148G3589
			2	148G3590
			3	148G3714
100	4	KDC 100	0.5	148G3593
			2	148G3594
			3	148G3715
125	5	KDC 125	0.5	148G3597
			2	148G3598
			3	148G3716
150	6	KDC 150	0.5	148G3601
			2	148G3602
200	8	KDC 200	0.5	148G3605
			2	148G3606

Table 9: Standard KDC with welding branches - ANSI

Size		Type	bar	Code no.
mm	in.			
65	2½	KDC 65	0.5	148G3587
			2	148G3588
			3	148G3811
80	3	KDC 80	0.5	148G3591
			2	148G3592
			3	148G3812
100	4	KDC 100	0.5	148G3595
			2	148G3596
			3	148G3813
125	5	KDC 125	0.5	148G3599
			2	148G3600
150	6	KDC 150	0.5	148G3603
			2	148G3604
200	8	KDC 200	0.5	148G3607
			2	148G3608

NOTE:

The HYDROCARBON versions of the KDC valves are not compatible with Ammonia as refrigerant. They can only be used in systems with HYDROCARBON as refrigerant.

Table 10: Hydrocarbon KDC with welding branches - ANSI

Size		Type	bar	Code no.
mm	in.			
65	2½	KDC 65	0.5	148G3825
			2	148G3831
80	3	KDC 80	0.5	148G3826
			2	148G3832
100	4	KDC 100	0.5	148G3827
			2	148G3833
125	5	KDC 125	0.5	148G3828
			2	148G3834
150	6	KDC 150	0.5	148G3829
			2	148G3835
200	8	KDC 200	0.5	148G3830
			2	148G3836

Spare parts and accessories

Table 11: Spare parts

Type	Code no.
GASKET BONNET/HOUSING KDC/GVD 65	148G3048
GASKET BONNET/HOUSING KDC/GVD 80	148G3049
GASKET BONNET/HOUSING KDC/GVD 100	148G3050
GASKET BONNET/HOUSING KDC/GVD 125	148G3051
GASKET BONNET/HOUSING KDC/GVD 150	148G3052
GASKET BONNET/HOUSING KDC/GVD 200	148G3053

Table 12: Seal kit

Type	Code no.
SEAL KIT SET KDC/GVD 65	148G3054
SEAL KIT SET KDC/GVD 80	148G3055
SEAL KIT SET KDC/GVD 100	148G3056
SEAL KIT SET KDC/GVD 125	148G3057
SEAL KIT SET KDC/GVD 150	148G3058
SEAL KIT SET KDC/GVD 200	148G3059

Table 13: Seal kit

Type	Code no.
SEAL KIT SET KDC/GVD 65 Hydrocarbon	148G3837
SEAL KIT SET KDC/GVD 80 Hydrocarbon	148G3838
SEAL KIT SET KDC/GVD 100 Hydrocarbon	148G3839
SEAL KIT SET KDC/GVD 125 Hydrocarbon	148G3840
SEAL KIT SET KDC/GVD 150 Hydrocarbon	148G3841
SEAL KIT SET KDC/GVD 200 Hydrocarbon	148G3842

NOTE:

The HYDROCARBON versions of the seal kits are not compatible with Ammonia as refrigerant. They can only be used in systems with HYDROCARBON as refrigerant.

The seal kit

Figure 10: The seal kit

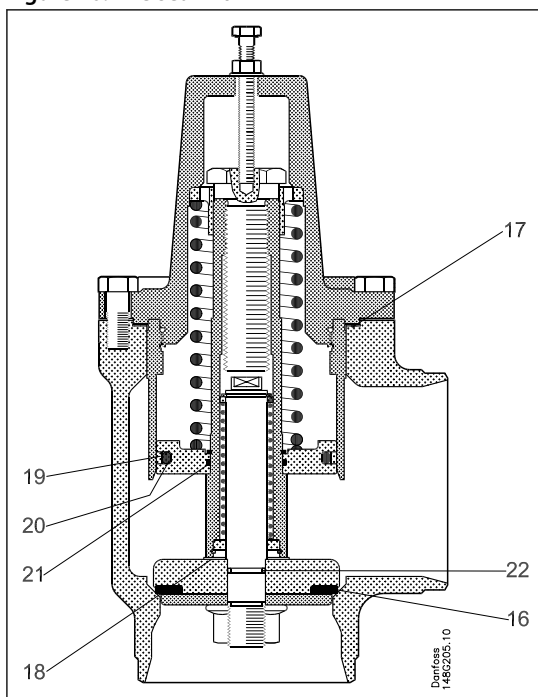

Pressure control valve, type KDC 65-200

Table 14: The seal kit

No.	Part	Material
16	Teflon ring	PTFE
17	Gasket	Fiber gasket non-asbestos
18	Washer	Nylon
19	Glide ring	PTFE
20-22	O-ring - Standard valve - Hydrocarbon valve	Cloroprene (Neoprene) Viton

Certificates, declarations, and approvals

The list contains all certificates, declarations, and approvals for this product type. Individual code number may have some or all of these approvals, and certain local approvals may not appear on the list.

Some approvals may change over time. You can check the most current status at danfoss.com or contact your local Danfoss representative if you have any questions.

Table 15: Pressure Equipment Directive (PED)

	<p>KDC valves are approved according to the European standard specified in the Pressure Equipment Directive and are CE marked.</p>
---	--

For further details / restrictions - see Installation Instruction.

Table 16: KDC valves

KDC valves			
Nominal bore	DN65-80 mm (1¼ - 3 in.)	DN100 - 200 mm (4-8 in.)	
Classified for	Fluid group I		
Category	II	III	
File name	Document type	Document topic	Approval authority
RU Д-DK.БЛ08.В.00191_18	EAC Declaration	Machinery & Equipment	EAC
0045 202 1204 Z 00354 19 D 001(00)	Pressure - Safety Certificate	-	TÜV
03709-F0 BV	Marine - Safety Certificate	-	BV
TSX71002520151142	Manufacturing Permission	-	GMPI
RU Д-DK.РА01.В.72054_20	EAC Declaration	PED	EAC
RU C-DK.БЛ08.В.01093_20	Pressure - Safety Certificate	PED	EAC
GL TAP0000001 Rev. 1	Marine - Safety Certificate	-	DNV GL
033F0685.AK	EU Declaration	EMCD/PED	Danfoss
033F0691.AE	Manufacturers Declaration	RoHS	Danfoss
0045 202 1204 Z 00355 19 D 001(00)	Pressure - Safety Certificate	-	TÜV
19.10048.266	Marine - Safety Certificate	-	RMRS

Online support

Danfoss offers a wide range of support along with our products, including digital product information, software, mobile apps, and expert guidance. See the possibilities below.

The Danfoss Product Store



The Danfoss Product Store is your one-stop shop for everything product related—no matter where you are in the world or what area of the cooling industry you work in. Get quick access to essential information like product specs, code numbers, technical documentation, certifications, accessories, and more.

Start browsing at store.danfoss.com.

Find technical documentation



Find the technical documentation you need to get your project up and running. Get direct access to our official collection of data sheets, certificates and declarations, manuals and guides, 3D models and drawings, case stories, brochures, and much more.

Start searching now at www.danfoss.com/en/service-and-support/documentation.

Danfoss Learning



Danfoss Learning is a free online learning platform. It features courses and materials specifically designed to help engineers, installers, service technicians, and wholesalers better understand the products, applications, industry topics, and trends that will help you do your job better.

Create your Danfoss Learning account for free at www.danfoss.com/en/service-and-support/learning.

Get local information and support



Local Danfoss websites are the main sources for help and information about our company and products. Find product availability, get the latest regional news, or connect with a nearby expert—all in your own language.

Find your local Danfoss website here: www.danfoss.com/en/choose-region.

Spare Parts



Get access to the Danfoss spare parts and service kit catalog right from your smartphone. The app contains a wide range of components for air conditioning and refrigeration applications, such as valves, strainers, pressure switches, and sensors.

Download the Spare Parts app for free at www.danfoss.com/en/service-and-support/downloads.

Coolselector®2 - find the best components for you HVAC/R system



Coolselector®2 makes it easy for engineers, consultants, and designers to find and order the best components for refrigeration and air conditioning systems. Run calculations based on your operating conditions and then choose the best setup for your system design.

Download Coolselector®2 for free at coolselector.danfoss.com.

Danfoss A/S

Climate Solutions • danfoss.com • +45 7488 2222

Any information, including, but not limited to information on selection of product, its application or use, product design, weight, dimensions, capacity or any other technical data in product manuals, catalogues descriptions, advertisements, etc. and whether made available in writing, orally, electronically, online or via download, shall be considered informative, and is only binding if and to the extent, explicit reference is made in a quotation or order confirmation. Danfoss cannot accept any responsibility for possible errors in catalogues, brochures, videos and other material. Danfoss reserves the right to alter its products without notice. This also applies to products ordered but not delivered provided that such alterations can be made without changes to form, fit or function of the product.

All trademarks in this material are property of Danfoss A/S or Danfoss group companies. Danfoss and the Danfoss logo are trademarks of Danfoss A/S. All rights reserved.