

TL3G Universal Compressor R134a 220-240V 50Hz

Data Sheet (Replaces CD.42.J5.02)

General

Compressor	TL3G
Code number	102G4350
Code number (UL-recognized)	102G4351

Application

Application		LBP/HBP
Evaporating temperature range	°C	-30 to 15
Voltage range	V/Hz	LBP: 187 - 254 /50
		LBP: 198 - 254 /60
		HBP: 198 - 254 /50
Motor type		RSIR/CSIR
Max. ambient temperature	°C	43
Comp. cooling at ambient temp.	32°C	LBP: S
		HBP: F ₂
	38°C	LBP: S
		HBP: F ₂
43°C	LBP: S	
	HBP: F ₂	

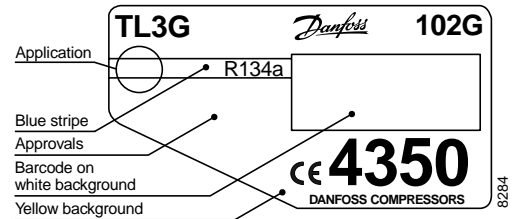

- S = Static cooling normally sufficient
- O = Oil cooling
- F₁ = Fan cooling 1.5 m/s
(compressor compartment temperature equal to ambient temperature)
- F₂ = Fan cooling 3.0 m/s necessary

Design

Displacement	cm ³	3.13
Oil quantity	cm ³	280
Maximum refrigerant charge	g	400
Free gas vol. in compressor	cm ³	1500
Weight without electrical equipment	kg	6.8

Motor

Motor size	watt	95
LRA (rated after 4 sec. UL984) LST/HST	A	3.5/4.9
Cut-in current LST/HST	A	8.0/4.9
Resistance, main and start winding (25°C)	Ω	24.3/15.5
Approvals (102G4350)		EN 60335-2-34
Approvals (102G4351)		UL984/CSA-C22.2, EN 60335-2-34

Dimensions

Height	mm	A	163
		B	159
Suction connector	location/I.D. mm	C	6.2 ±0.09
Process connector	location/I.D. mm	D	6.2 ±0.09
Discharge connector	location/I.D. mm	E	5.0 +0.12/+0.20
Compressors on a pallet	pcs.		125

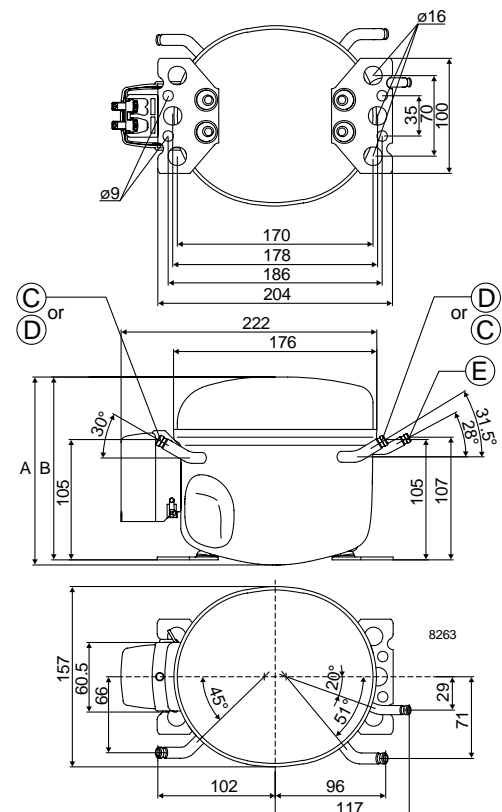

Capacity (EN 12900/CECOMAF)

watt

Evap. temp in °C	-30	-25	-23.3	-20	-15	-10	-5	0	5	7.2	10	15
TL3G, 50Hz	25.3	40.9	46.7	59.1	80.5	106	136	170	211	231	258	312
TL3G, 60Hz	29.5	47.4	54.3	68.9	94.6	125						

Capacity (ASHRAE)

watt

Evap. temp in °C	-30	-25	-23.3	-20	-15	-10	-5	0	5	7.2	10	15
TL3G, 50Hz	31.2	50.4	57.7	72.9	99.4	131	168	211	262	287	321	388
TL3G, 60Hz	36.3	58.4	66.9	85.0	117	155						

Power consumption

watt

Evap. temp in °C	-30	-25	-23.3	-20	-15	-10	-5	0	5	7.2	10	15
TL3G, 50Hz	57.7	65.8	68.8	75.0	85.2	96.2	108	120	133	139	146	159
TL3G, 60Hz	60.0	69.7	73.5	81.0	95.0	111						

Current consumption

A

Evap. temp in °C	-30	-25	-23.3	-20	-15	-10	-5	0	5	7.2	10	15
TL3G, 50Hz	0.68	0.70	0.70	0.72	0.74	0.77	0.80	0.84	0.88	0.89	0.92	0.97
TL3G, 60Hz	0.60	0.63	0.64	0.66	0.70	0.74						

COP (EN 12900/CECOMAF)

W/W

Evap. temp in °C	-30	-25	-23.3	-20	-15	-10	-5	0	5	7.2	10	15
TL3G, 50Hz	0.44	0.62	0.68	0.79	0.95	1.10	1.26	1.42	1.59	1.67	1.77	1.96
TL3G, 60Hz	0.49	0.68	0.74	0.85	0.99	1.13						

COP (ASHRAE)

W/W

Evap. temp in °C	-30	-25	-23.3	-20	-15	-10	-5	0	5	7.2	10	15
TL3G, 50Hz	0.54	0.77	0.84	0.97	1.17	1.36	1.56	1.76	1.97	2.07	2.20	2.44
TL3G, 60Hz	0.61	0.84	0.91	1.04	1.23	1.39						

Test conditions

EN 12900/CECOMAF

ASHRAE

Condensing temperature

55°C

55°C

Ambient and suction gas temp.

32°C

32°C

Liquid temperature

55°C

32°C

50Hz: Static cooling, 220V

60Hz: Static cooling, 220V

Accessories

Devices	Fig.	TL3G
PTC starting device 6.3 mm spades 4.8 mm spades	a1	103N0011 103N0018
Starting relay	a2	117U6009
Cover (102G4350)	b	103N2010
Cover (102G4351)	b	103N2011
Starting capacitor 60 µF	c	117U5014
Cord relief	d	103N1010
Protection screen for PTC	g	103N0476
Mounting accessories		
Bolt joint for one compressor		118-1917
Bolt joint in quantities		118-1918
Snap-on in quantities		118-1919

