

Midea Xtreme Save

FICHE PRODUIT

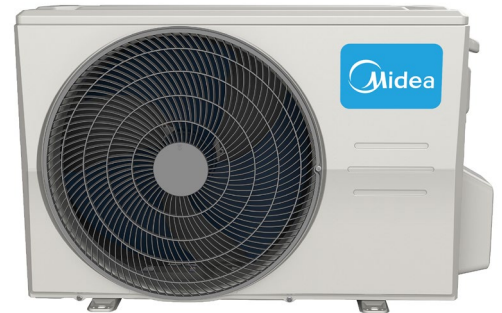

RG10A(B2S)/BGEF
Télécommande incluse



Produit certifié par:



CARACTÉRISTIQUES

Modèle	XTREME SAVE 26(09)N8 ⁽³⁾	XTREME SAVE 35(12)N8 ⁽³⁾	XTREME SAVE 52(18)N8I	XTREME SAVE 71(24)N8I
Puissance frigorifique	2,64 kW	3,52 kW	5,28 kW	7,03 kW
Consommation froid	659 W	1.004 W	1.550 W	2.402 W
Puissance calorifique	2,93 kW	3,81 kW	5,57 kW	7,33 kW
Consommation chaud	674 W	969 W	1.750 W	2.130 W
Clas. ErP froid/chaud	A+++ / A+	A+++ / A+	A++ / A+	A++ / A+
Débit d'air (int.)	300/360/510 m ³ /h	310/370/520 m ³ /h	500/600/800 m ³ /h	610/770/1.090 m ³ /h
Pression sonore (int.)	22 dB(A)	22 dB(A)	31 dB(A)	34,50 dB(A)
Débit d'air (ext.)	2.150 m ³ /h	2.200 m ³ /h	2.100 m ³ /h	3.500 m ³ /h
Pression sonore (ext.)	55,50 dB(A)	55 dB(A)	57 dB(A)	60 dB(A)
Alimentation	220-240 V / 1 / 50 Hz			
Câble alimentation (ext.)	(2+T)x1,50 mm ²	(2+T)x1,50 mm ²	(2+T)x1,50 mm ²	(2+T)x2,50 mm ²
Câble interconnexion	(4+T)x1,50 mm ²	(4+T)x1,50 mm ²	(4+T)x1,50 mm ²	(4+T)x2,50 mm ²
Tuyaux réfrigérants	Ø1/4" / Ø3/8"	Ø1/4" / Ø3/8"	Ø1/4" / Ø1/2"	Ø3/8" / Ø5/8"
Charge d'usine / Charge additionnelle	0,62 kg / 0,012 kg	0,62 kg / 0,012 kg	1,10 kg / 0,012 kg	1,45 kg / 0,024 kg
Longueur max. tuyau	25 m	25 m	30 m	50 m
Hauteur max.	10 m	10 m	20 m	25 m

SCHÉMA CONNEXIONS



Schéma de connexion Multi-function board

NOTES:
 (1) Les données et spécifications présentes sur cette fiche peuvent varier sans préavis.
 (2) Les images sur cette fiche sont indicatives et peuvent être différentes de la machine finale.
 (3) Les modèles indiqués ne disposent pas de Midea Proactive Pure.

DIMENSIONS ET POIDS UNITÉ INTÉRIEURE

Modèle	Poids	W	H	D
MSAGBU-09HRFN8-QRD1GW(GA)	8,70 kg	835 mm	295 mm	208 mm
MSAGBU-12HRFN8-QRD1GW(GA)	8,70 kg	835 mm	295 mm	208 mm
MSAGCU-18HRFN8-QRDOGW-I	11,20 kg	969 mm	320 mm	241 mm
MSAGDU-24HRFN8-QRDOGW-I	13,60 kg	1.083 mm	336 mm	244 mm

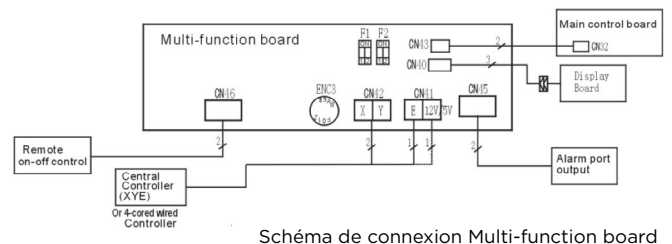
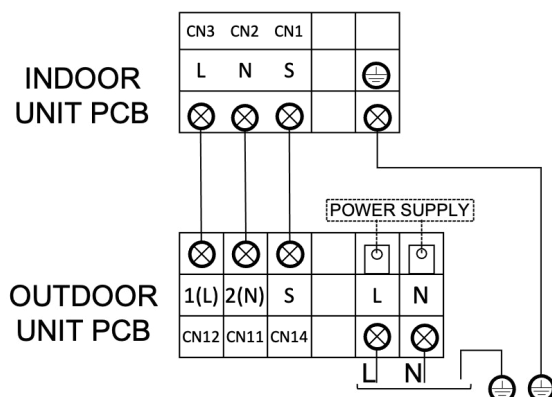
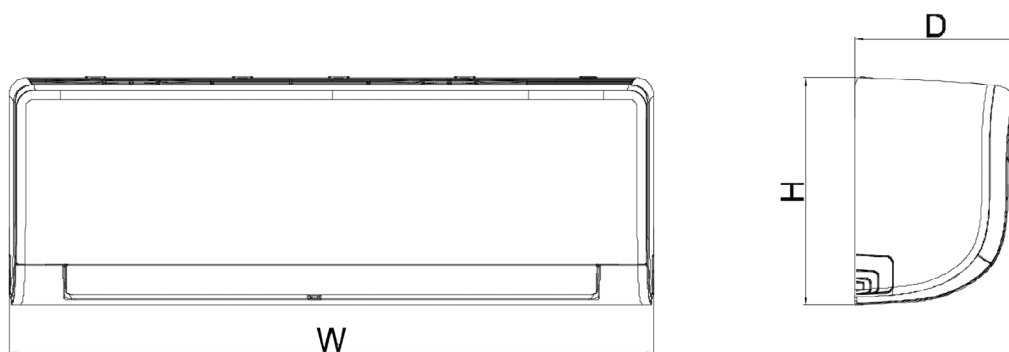

DIMENSIONS ET POIDS UNITÉ EXTÉRIEURE

Modèle	Poids	W	H	D
MOX201-09HFN8-QRD1GW	26,20 kg	765 mm	555 mm	303 mm
MOX201-12HFN8-QRD1GW	26,20 kg	765 mm	555 mm	303 mm
MOX301-18HFN8-QRDOGW	33,50 kg	874 mm	554 mm	330 mm
MOX401-24HFN8-QRDOGW	43,90 kg	955 mm	673 mm	342 mm

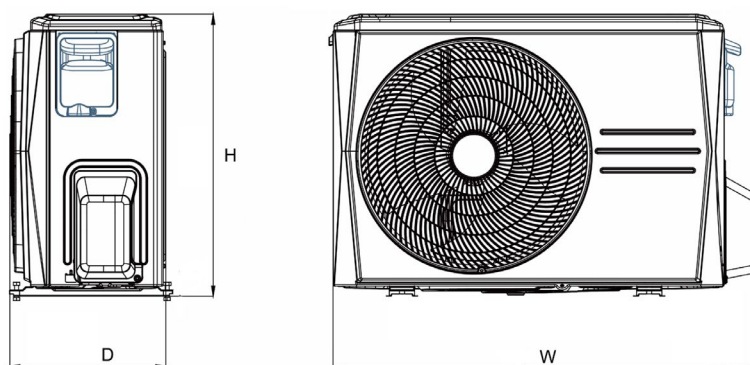

INSTALLATION

