

EVD evolution twin

Driver for 2 electronic expansion valves



ENG User manual

**LEGGI E CONSERVA
QUESTE ISTRUZIONI**
**READ AND SAVE
THESE INSTRUCTIONS**

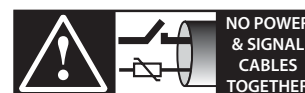

**NO POWER
& SIGNAL
CABLES
TOGETHER**
READ CAREFULLY IN THE TEXT!

WARNINGS



CAREL INDUSTRIES bases the development of its products on decades of experience in HVAC, on the continuous investments in technological innovations to products, procedures and strict quality processes with in-circuit and functional testing on 100% of its products, and on the most innovative production technology available on the market. CAREL INDUSTRIES and its subsidiaries/affiliates nonetheless cannot guarantee that all the aspects of the product and the software included with the product respond to the requirements of the final application, despite the product being developed according to start-of-the-art techniques. The customer (manufacturer, developer or installer of the final equipment) accepts all liability and risk relating to the configuration of the product in order to reach the expected results in relation to the specific final installation and/or equipment.

CAREL INDUSTRIES may, based on specific agreements, acts as a consultant for the successful commissioning of the final unit/application, however in no case does it accept liability for the correct operation of the final equipment/system.

The CAREL INDUSTRIES product is a state-of-the-art product, whose operation is specified in the technical documentation supplied with the product or can be downloaded, even prior to purchase, from the website www.carel.com.

Each CAREL INDUSTRIES product, in relation to its advanced level of technology, requires setup/configuration/programming/commissioning to be able to operate in the best possible way for the specific application. The failure to complete such operations, which are required/indicated in the user manual, may cause the final product to malfunction; CAREL INDUSTRIES accepts no liability in such cases. Only qualified personnel may install or carry out technical service on the product. The customer must only use the product in the manner described in the documentation relating to the product.

In addition to observing any further warnings described in this manual, the following warnings must be heeded for all CAREL INDUSTRIES products:

- prevent the electronic circuits from getting wet. Rain, humidity and all types of liquids or condensate contain corrosive minerals that may damage the electronic circuits. In any case, the product should be used or stored in environments that comply with the temperature and humidity limits specified in the manual;
- do not install the device in particularly hot environments. Too high temperatures may reduce the life of electronic devices, damage them and deform or melt the plastic parts. In any case, the product should be used or stored in environments that comply with the temperature and humidity limits specified in the manual;
- do not attempt to open the device in any way other than described in the manual;
- do not drop, hit or shake the device, as the internal circuits and mechanisms may be irreparably damaged;
- do not use corrosive chemicals, solvents or aggressive detergents to clean the device;
- do not use the product for applications other than those specified in the technical manual.

All of the above suggestions likewise apply to the controllers, serial boards, programming keys or any other accessory in the CAREL INDUSTRIES product portfolio.

CAREL INDUSTRIES adopts a policy of continual development. Consequently, CAREL INDUSTRIES reserves the right to make changes and improvements to any product described in this document without prior warning. The technical specifications shown in the manual may be changed without prior warning.

The liability of CAREL INDUSTRIES in relation to its products is specified in the CAREL INDUSTRIES general contract conditions, available on the website www.carel.com and/or by specific agreements with customers; specifically, to the extent where allowed by applicable legislation, in no case will CAREL INDUSTRIES, its employees or subsidiaries/affiliates be liable for any lost earnings or sales, losses of data and information, costs of replacement goods or services, damage to things or people, downtime or any direct, indirect, incidental, actual, punitive, exemplary, special or consequential damage of any kind whatsoever, whether contractual, extra-contractual or due to negligence, or any other liabilities deriving from the installation, use or impossibility to use the product, even if CAREL INDUSTRIES or its subsidiaries are warned of the possibility of such damage.

DISPOSAL



INFORMATION FOR USERS ON THE CORRECT HANDLING OF WASTE ELECTRICAL AND ELECTRONIC EQUIPMENT (WEEE)

In reference to European Union directive 2002/96/EC issued on 27 January 2003 and the related national legislation, please note that:

1. WEEE cannot be disposed of as municipal waste and such waste must be collected and disposed of separately;
2. the public or private waste collection systems defined by local legislation must be used. In addition, the equipment can be returned to the distributor at the end of its working life when buying new equipment;
3. the equipment may contain hazardous substances: the improper use or incorrect disposal of such may have negative effects on human health and on the environment;
4. the symbol (crossed-out wheeled bin) shown on the product or on the packaging and on the instruction sheet indicates that the equipment has been introduced onto the market after 13 August 2005 and that it must be disposed of separately;
5. in the event of illegal disposal of electrical and electronic waste, the penalties are specified by local waste disposal legislation.

Warranty on the materials: 2 years (from the date of production, excluding consumables).

Approval: the quality and safety of CAREL INDUSTRIES products are guaranteed by the ISO 9001 certified design and production system.

IMPORTANT: Separate as much as possible the probe and digital input cables from the cables to inductive loads and power cables to avoid possible electromagnetic disturbance.

Never run power cables (including the electrical panel cables) and signal cables in the same conduits

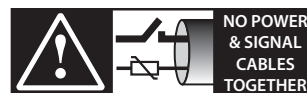

NO POWER & SIGNAL CABLES TOGETHER

READ CAREFULLY IN THE TEXT!

Contents

1. INTRODUCTION	7		
1.1 Models	7		
1.2 Main functions and features.....	7		
2. INSTALLATION	9		
2.1 DIN rail assembly and dimensions	9		
2.2 Description of the terminals.....	9		
2.3 Connection diagram - superheat control.....	9		
2.4 Installation	10		
2.5 Valve operation in parallel and complementary mode	10		
2.6 Shared pressure probe.....	11		
2.7 Connecting the USB-tLAN converter	11		
2.8 Connecting the USB/RS485 converter.....	12		
2.9 Upload, Download and Reset parameters (display).....	12		
2.10 Display electrical connections (display).....	12		
2.11 General connection diagram.....	13		
3. USER INTERFACE	14		
3.1 Assembling the display board (accessory)	14		
3.2 Display and keypad.....	14		
3.3 Switching between drivers (display).....	15		
3.4 Display mode (display).....	15		
3.5 Programming mode (display).....	15		
4. COMMISSIONING	17		
4.1 Commissioning	17		
4.2 Guided commissioning procedure (display).....	17		
4.3 Checks after commissioning.....	19		
4.4 Other functions	19		
5. CONTROL	20		
5.1 Main control.....	20		
5.2 Superheat control.....	20		
5.3 Adaptive control and autotuning.....	22		
5.4 Control with Emerson Climate Digital Scroll™ compressor	23		
5.5 Special control	24		
6. FUNCTIONS	28		
6.1 Power supply mode	28		
6.2 Network connection	28		
6.3 Inputs and outputs	28		
6.4 Control status	30		
6.5 Special control status.....	31		
7. PROTECTORS	33		
7.1 Protectors	33		
8. TABLE OF PARAMETERS	35		
8.1 Table of parameters, driver A	35		
8.2 Table of parameters, driver B.....	40		
8.3 Unit of measure.....	44		
8.4 Variables accessible via serial – driver A.....	45		
8.5 Variables accessible via serial – driver B.....	46		
8.6 Variables used based on the type of control	47		
9. ALARMS	48		
9.1 Alarms	48		
9.2 Alarm relay configuration	49		
9.3 Probe alarms.....	49		
9.4 Control alarms.....	50		
9.5 EEV motor alarm	50		
9.6 LAN error alarm	50		
10. TROUBLESHOOTING	51		
11. TECHNICAL SPECIFICATIONS	53		
12. APPENDIX: VPM (VISUAL PARAMETER MANAGER)	54		
12.1 Installation	54		
12.2 Programming (VPM).....	54		
12.3 Copying the setup	55		
12.4 Setting the default parameters	55		
12.5 Updating the controller and display firmware	55		

1. INTRODUCTION

EVD evolution twin is a controller featuring two drivers for double pole stepper motors that independently manages two electronic expansion valves. It is designed for DIN rail assembly and is fitted with plug-in screw terminals. Each driver controls refrigerant superheat and optimises the efficiency of the refrigerant circuit, guaranteeing maximum flexibility, being compatible with various types of refrigerants and valves, in applications with chillers, air-conditioners and refrigerators, the latter including subcritical and transcritical CO₂ systems. It features low superheat (LowSH), high evaporation pressure (MOP), and low evaporation pressure (LOP) protection, and can manage, as an alternative to superheat control, special functions such as the hot gas bypass, evaporator pressure regulation (EPR) and control of the valve downstream of the gas cooler in transcritical CO₂ circuits. The controller can drive an electronic expansion valve in a refrigerant circuit with Digital Scroll compressor, if integrated with a specific CAREL controller via LAN. In addition, it features adaptive control that can evaluate the effectiveness of superheat control and if necessary activate one or more tuning procedures. As regards network connectivity, the controller can be connected to either of the following:

- a pCO programmable controller to manage the controller via pLAN, tLAN and RS485/Modbus*;
- a PlantVisorPRO supervisor via RS485/Modbus*. In this case, On/Off control is performed via digital input 1 for driver A and via digital input 2 for driver B, if suitably configured. As well as regulation start/stop, digital inputs 1 and 2 can be configured for the following:
 - valve regulation optimization after defrost;
 - discharged battery alarm management;
 - valve forced open (at 100%);
 - regulation backup;
 - regulation security.
- The last two possibilities refer to the behaviour of the driver when there is no communication over the pLAN or tLAN, RS485/Modbus* network (see chap. 6).

Another possibility involves operation as a simple positioner with 4 to 20 mA or 0 to 10 Vdc analogue input signal for driver A (inputs S1 and S2 respectively) and with 4 to 20 mA signal for driver B (input S3). EVD evolution twin comes with a LED board to indicate the operating status, or a graphic display (accessory) that can be used to perform installation, following a guided commissioning procedure involving setting just 4 parameters for each driver: refrigerant, valve, pressure sensor, type of main control (chiller, showcase, etc.). The procedure can also be used to check that the sensor and valve motor wiring is correct. Once installation is complete, the display can be removed, as it is not necessary for the operation of the controller, or alternatively kept in place to display the significant system variables, any alarms and when necessary set the control parameters. The controller can also be setup using a computer via the service serial port. In this case, the VPM program (Visual Parameter Manager) needs to be installed, downloadable from <http://ksa.carel.com>, and the USB-tLAN converter EVDNCNV00E0 connected. Only on RS485/Modbus* models can installation be managed as described above by computer, using the serial port (see paragraph 2.6) in place of the service serial port. The "universal" models can drive all types of valves, while the "CAREL" models only drive CAREL valves.

1.1 Models

Code	Description
EVD0000T00	EVD evolution twin universal (tLAN)
EVD0000T01	EVD evolution twin universal (tLAN) pack of 10 pcs. (*)
EVD0000T10	EVD evolution twin universal (pLAN)
EVD0000T11	EVD evolution twin universal (pLAN) pack of 10 pcs. (*)
EVD0000T20	EVD evolution twin universal (RS485/Modbus*)
EVD0000T21	EVD evolution twin universal (RS485/Modbus*) pack of 10 pcs. (*)
EVD0000T30	EVD evolution twin for Carel valves (tLAN)
EVD0000T31	EVD evolution twin for Carel valves (tLAN) pack of 10 pcs. (*)
EVD0000T40	EVD evolution twin for Carel valves (pLAN)
EVD0000T41	EVD evolution twin for Carel valves (pLAN) pack of 10 pcs. (*)
EVD0000T50	EVD evolution twin for Carel valves (RS485/Modbus*)
EVD0000T51	EVD evolution twin for Carel valves (RS485/Modbus*) pack of 10 pcs. (*)
EVDCON0021	EVD Evolution, connector kit (10pcs) for multi-pack(*)

Tab. 1.a

(*)The codes with multiple packages are sold without connectors, available separately in code EVDCON0021.

1.2 Main functions and features

In summary:

- electrical connections by plug-in screw terminals;
- serial card incorporated in the controller, based on the model (tLAN, pLAN, RS485/Modbus*);
- compatibility with various types of valves ("universal" models only) and refrigerants;
- activation/deactivation of control via digital input 1 for driver A and digital input 2 for driver B, if suitably configured, or remote control via LAN, from pCO programmable controller;
- superheat control with protection functions for low superheat LowSH, MOP, LOP;
- adaptive superheat control;
- function to optimise superheat control for air-conditioning units fitted with Emerson Climate Digital Scroll compressor. In this case, EVD Evolution twin must be connected to a CAREL pCO series controllers running an application program that can manage units with Digital Scroll compressors. This function is only available on the controllers for CAREL valves;
- configuration and programming by display (accessory), by computer using the VPM program or by PlantVisor/PlantVisorPro supervisor and pCO programmable controller;
- commissioning simplified by display with guided procedure for setting the parameters and checking the electrical connections;
- multi-language graphic display, with "help" function on various parameters;
- management of different units of measure (metric/imperial);
- parameters protected by password, accessible at a service (installer) and manufacturer level;
- copy the configuration parameters from one EVD evolution twin controller to another using the removable display;
- ratiometric or electronic 4 to 20 mA pressure transducer, the latter can be shared between up to 5 drivers (maximum 2 EVD evolution twins + 1 EVD Evolution), useful for multiplexed applications;
- 4 to 20 mA or 0 to 10 Vdc input to use the controller as a positioner controlled by an external signal;
- management of power failures with valve closing (only for controllers with 24 Vac power supply connected to EVBAT00400/EVBAT00500 accessory);
- advanced alarm management.

For software versions higher than 4.0, the following new functions have been introduced:

- 24 Vac or 24 Vdc power supply, in the latter case without valve closing in the event of power failures;
- pre-position time settable by parameter;
- use of digital to start/stop control when there is no communication with the pCO programmable controller.

Series of accessories for EVD evolution twin

Display (code EVDIS000)**

Easily applicable and removable at any time from the front panel of the controller, during normal operation displays all the significant variables for system A and B, the status of the relay outputs and recognises the activation of the protection functions and alarms. During commissioning, it guides the installer in setting the parameters required to start the installations and, once completed, can copy the parameters to other EVD evolution twin controllers. The models differ in the first settable language, the second language for all models is English. EVDIS00**0 can be used to configure and monitor all the control parameters for both drivers, accessible via password at a service (installer) and manufacturer level.



Fig. 1.a

USB/tLAN converter (code EVDCNV00E0)

The USB-tLAN converter is connected, once the LED board cover has been removed, to the service serial port underneath. Fitted with cables and connectors, it can connect EVD evolution twin directly to a computer, which, using the VPM program, can configure and program the controller. VPM can also be used to update the controller and display firmware. See the appendix.



Fig. 1.b

USB/RS485 converter (code CVSTDUMOR0)

The converter is used to connect the configuration computer and the EVD evolution twin controllers, for RS485/Modbus® models only.



Fig. 1.c

⚠ Important: the EVBAT00400 battery module can only be used with 24 Vac power supply.

Battery module (code EVBAT00400)

The EVBAT00400 module is an electronic device made by CAREL which guarantees temporary power supply to the EVD0000T* driver (only one controller can be connected), in the event of a sudden power failure. It signals the battery discharged or faulty status via an open collector output, which can be used by the pCO to generate an alarm message and notify the technical service for preventive maintenance. Powered by a 12 V lead backup battery, it supplies 12 Vdc to the controller for the time required to completely close the electronic valve being controlled, while during normal operation ensures the battery is correctly recharged. The battery (code EVBAT00500) and the box (code EVBATBOX*0) can be purchased separately.



EBVAT00400



EVBAT00500

Fig. 1.d

Valve cable E2VCABS*00 (IP67)

Shielded cable with built-in connector for connection to the valve motor. The connector code E2VCON0000 (IP65) can also be purchased on its own, to be wired.



Fig. 1.e

2. INSTALLATION

2.1 DIN rail assembly and dimensions

EVD evolution twin è fornito con connettori serigrafati per facilitare i collegamenti elettrici. Gli schermi dei due cavi valvola vanno collegati all'unico terminale tipo fast-on.

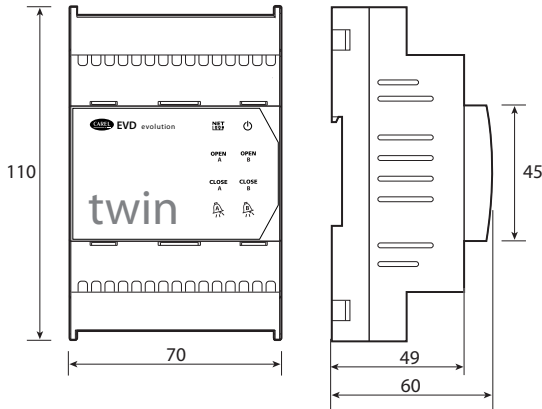

Fig. 2.a

2.2 Description of the terminals

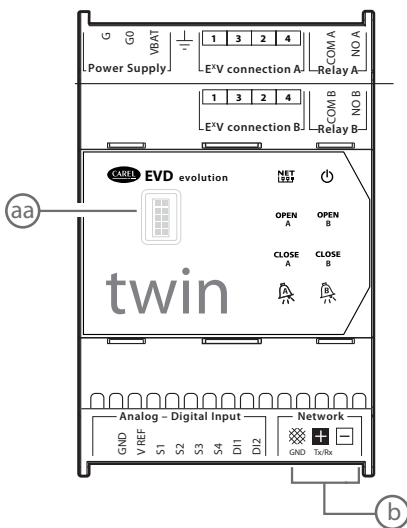

Fig. 2.b

Terminal	Description
G,G0	Power supply
VBAT	Emergency power supply
	Functional earth
1,3,2,4: ExV connection A	Stepper motor power supply driver A
COM A, NO A	Alarm relay driver A
1,3,2,4: ExV connection B	Stepper motor power supply driver B
COM B, NO B	Alarm relay driver B
GND	Signal ground
VREF	Power supply to active probes
S1	Probe 1 (pressure) or 4 to 20mA external signal
S2	Probe 2 (temperature) or 0 to 10V external signal
S3	Probe 3 (pressure) or 4 to 20mA external signal
S4	Probe 4 (temperature)
DI1	Digital input 1
DI2	Digital input 2
	Terminal for tLAN, pLAN, RS485, ModBus® connection
	Terminal for tLAN, pLAN, RS485, ModBus® connection
	Terminal for pLAN, RS485, ModBus® connection
aa	service serial port (remove the cover for access)
b	serial port

Tab. 2.b

2.3 Connection diagram - superheat control

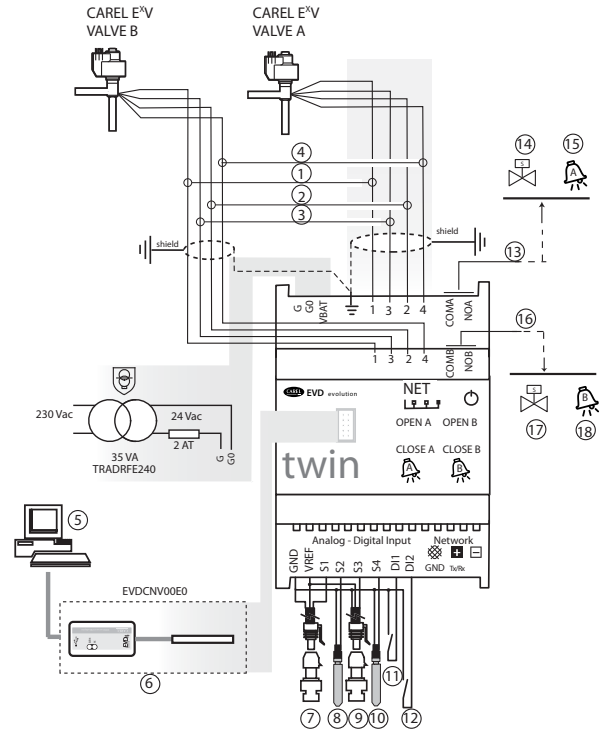

Fig. 2.c

Key:

1	green
2	yellow
3	brown
4	white
5	personal computer for configuration
6	USB/tLAN converter
7	ratiometric pressure transducer–evaporation pressure driver A
8	NTC – suction temperature driver A
9	ratiometric pressure transducer–evaporation pressure driver B
10	NTC – suction temperature driver B
11	digital input 1 configured to enable control driver A
12	digital input 2 configured to enable control driver B
13	voltage-free contact driver A (up to 230 V)
14	solenoid valve A
15	alarm signal A
16	voltage-free contact driver B (up to 230 V)
17	solenoid valve B
18	alarm signal B

Note:

- connect the shield of the two valve cables to the same spade connector;
- the use of driver A for superheat control requires the use of the evaporation pressure probe S1 and the suction temperature probe S2, which will be fitted after the evaporator, and digital input 1 to enable control. As an alternative to digital input 1, control can be enabled via remote signal (tLAN, pLAN, RS485). For the positioning of the probes relating to other applications, see the chapter on "Control";

- the use of driver B for superheat control requires the use of the evaporation pressure probe S3 and the suction temperature probe S4, which will be fitted after the evaporator, and digital input 2 to enable control. As an alternative to digital input 2, control can be enabled via remote signal (tLAN, pLAN, RS485). For the positioning of the probes relating to other applications, see the chapter on "Control";
- inputs S1, S2, S3 & S4 are programmable and the connection to the terminals depends on the setting of the parameters. See the chapters on "Commissioning" and "Functions";
- pressure probes S1 & S2 in the diagram are ratiometric. See the general connection diagram for the other electronic probes, 4 to 20 mA or combined;
- the pressure probes S1 and S3 must be of the same type.

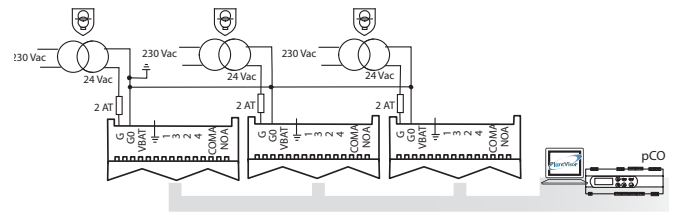

Fig. 2.f

2.4 Installation

For installation proceed as follows, with reference to the wiring diagrams:

1. connect the probes: the probes can be installed a maximum distance of 10 metres away from the controller, or a maximum of 30 metres as long as shielded cables are used with minimum cross-section of 1 mm² (connect all the shields to the earth spade connector);
2. connect any digital inputs, maximum length 30 m;
3. connect the power cable to the valve motors: use 4-wire shielded cable AWG 22 L_{max}=10 m or AWG 14 L_{max}=50m; failure to connect the valve motors after connecting the controller will generate the "EEV motor error" alarm: see paragraph 9.5;
4. carefully evaluate the maximum capacity of the relay outputs specified in the chapter "Technical specifications";
5. if necessary, use a class 2 safety transformer with suitable short-circuit and overload protection. For the power ratings of the transformer see the general connection diagram and the technical specifications;
6. the connection cables must have a minimum cross-section of 0.5 mm²;
7. power up the controller: for 24 Vdc power supply the controller will close the valves;

Important: for 24 Vdc power supply, set "Power supply mode" parameter=1 to start control. See par. 6.1

Case 1: multiple controllers connected in a network powered by the same transformer. Typical application for a series of controllers inside the same electrical panel

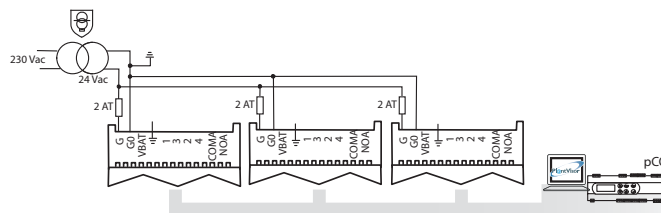

Fig. 2.d

Case 2: multiple controllers connected in a network powered by different transformers (G0 not connected to earth). Typical application for a series of controllers in different electrical panels.

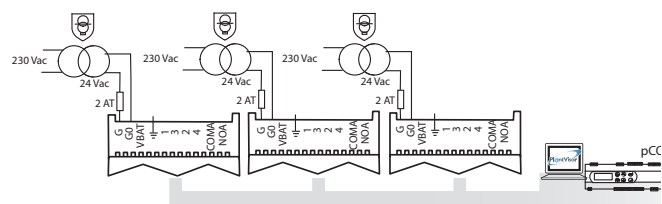

Fig. 2.e

Case 3: multiple controllers connected in a network powered by different transformers with just one earth point. Typical application for a series of controllers in different electrical panels.

Important: avoid installing the controller in environments with the following characteristics:

- relative humidity greater than the 90% or condensing;
- strong vibrations or knocks;
- exposure to continuous water sprays;
- exposure to aggressive and polluting atmospheres (e.g.: sulphur and ammonia fumes, saline mist, smoke) to avoid corrosion and/or oxidation;
- strong magnetic and/or radio frequency interference (avoid installing the appliances near transmitting antennae);
- exposure of the controller to direct sunlight and to the elements in general.

Important: When connecting the controller, the following warnings must be observed:

- if the controller is not used as specified in this user manual, the protection indicated is not guaranteed;
- do not operate the controller for extended periods without connecting both valves;
- incorrect connection to the power supply may seriously damage the controller;
- use cable ends suitable for the corresponding terminals. Loosen each screw and insert the cable ends, then tighten the screws and lightly tug the cables to check correct tightness;
- separate as much as possible (at least 3 cm) the probe and digital input cables from the power cables to the loads so as to avoid possible electromagnetic disturbance. Never lay power cables and probe cables in the same conduits (including those in the electrical panels);
- install the shielded valve motor cables in the probe conduits: use shielded valve motor cables to avoid electromagnetic disturbance to the probe cables;
- avoid installing the probe cables in the immediate vicinity of power devices (contactors, circuit breakers, etc.). Reduce the path of the probe cables as much as possible and avoid enclosing power devices;
- avoid powering the controller directly from the main power supply in the panel if this supplies different devices, such as contactors, solenoid valves, etc., which will require a separate transformer.
- * EVD EVO is a control to be incorporated in the end equipment, do not use for flush mount
- * DIN VDE 0100: Protective separation between SELV circuit and other circuits must be guaranteed. The requirements according to DIN VDE 0100 must be fulfilled. To prevent infringement of the protective separation (between SELV circuit to other circuits) an additional fixing has to be provided near to the terminals. This additional fixing shall clamp the insulation and not the conductor".

2.5 Valve operation in parallel and complementary mode

EVD evolution twin can control two CAREL valves connected together (see paragraph 4.2), in parallel mode, with identical behaviour, or in complementary mode, whereby if one valve opens, the other closes by the same percentage. To achieve such behaviour, simply set the "valve" parameter ("Two EXV connected together") and connect the valve motor power supply wires to the same connector. In the example shown below, for operation of valve B_2 with valve B_1 in complementary mode simply swap the connection of wires 1 and 3.

2 CAREL valves connected in parallel mode

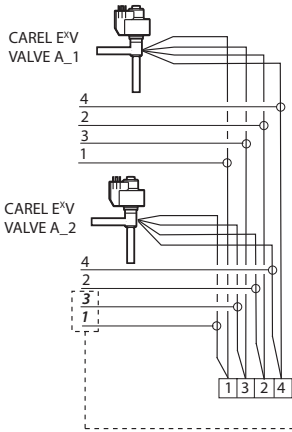
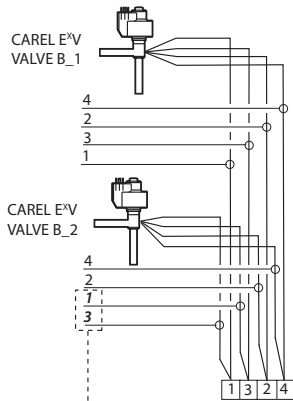

Fig. 2.g

2 CAREL valves connected in complementary mode



Note: operation in parallel and complementary mode can only be used for CAREL valves, within the limits shown in the table below, where OK means that the valve can be used with all refrigerants at the rated operating pressure

	Model of CAREL valve					
	E2V	E3V	E4V	E5V	E6V	E7V
Two EXV connected together	OK	OK	• E4V85 with all refrigerants except for R410A • E4V95 only with R134a	NO	NO	NO

Tab. 2.c

2.6 Shared pressure probe

Only 4 to 20 mA pressure probes (not ratiometric) can be shared. The probe can be shared by a maximum of 5 drivers. For multiplexed systems where twin1, twin2 and twin3 controllers share the same pressure probe, choose the normal option for driver A on the twin 1 controller and the "remote" option for the other drivers. Driver B on the twin3 controller must use another pressure probe, P2.

Example

	twin1	twin2	twin3
Probe S1 (driver A)	-0.5 to 7 barg (P1)	remote, -0.5 to 7 barg	remote, -0.5 to 7 barg
Probe S3 (driver B)	remote, -0.5 to 7 barg	remote, -0.5 to 7 barg	-0.5 to 7 barg (P2)

Tab. 2.d

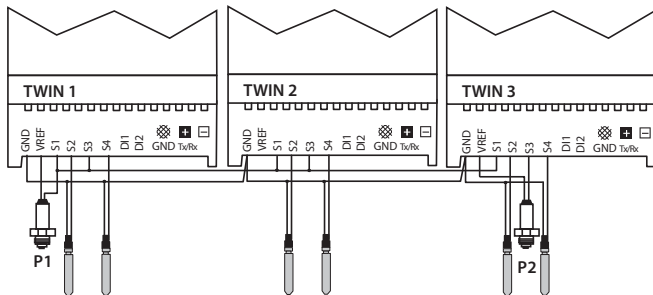

Fig. 2.h

Key:

P1	shared pressure probe
P2	pressure probe

2.7 Connecting the USB-tLAN converter

Procedure:

- remove the LED board cover by pressing on the fastening points;
- plug the adapter into the service serial port;
- connect the adapter to the converter and then this in turn to the computer
- power up the controller

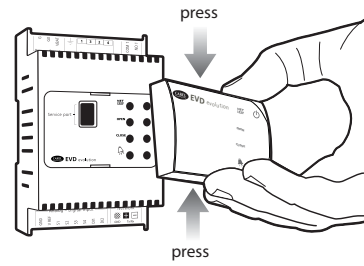

Fig. 2.i

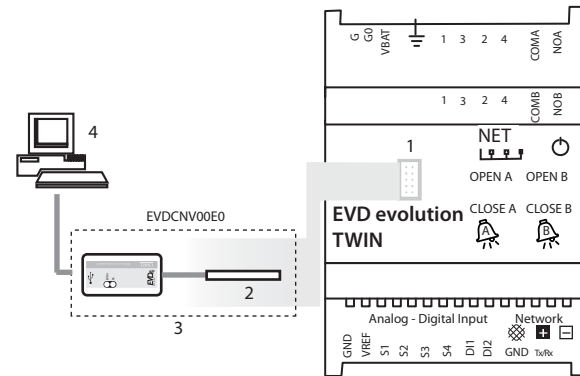

Fig. 2.j

Key:

1	service serial port
2	adapter
3	USB/tLAN converter
4	personal computer

Note: when using the service serial port connection, the VPM program can be used to configure the controller and update the controller and display firmware, downloadable from <http://ksa.carel.com>. See the appendix.

2.8 Connecting the USB/RS485 converter

Only on EVD evolution twin RS485/Modbus® models can the configuration computer be connected using the USB/RS485 converter and the serial port, according to the following diagram:

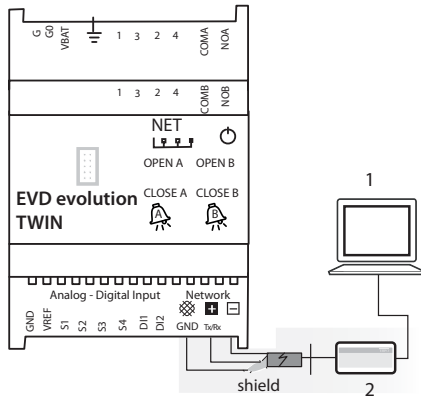

Fig. 2.k

Key:

1	personal computer for configuration
2	USB/RS485 converter

Note:

- the serial port can be used for configuration with the VPM program and for updating the controller firmware, downloadable from <http://ksa.carel.com>;
- to save time, up to 8 controllers EVD evolution twin can be connected to the computer, updating the firmware at the same time (each controller must have a different network address).

2.9 Upload, Download and Reset parameters (display)

Procedure:

1. press the Help and ENTER buttons together for 5 seconds;
 2. a multiple choice menu will be displayed, use UP/DOWN to select the required procedure;
 3. confirm by pressing ENTER;
 4. the display will prompt for confirmation, press ENTER;
 5. at the end a message will be shown to notify the operation if the operation was successful.
- UPLOAD: the display saves all the values of the parameters on the source controller;
 - DOWNLOAD: the display copies all the values of the parameters to the target controller;
 - RESET: all the parameters on the controller are restored to the default values.
 - See the table of parameters in chapter 8.



Fig. 2.l

Important:

- the procedure must be carried out with controller/controllers powered;
- DO NOT remove the display from the controller during the UPLOAD, DOWNLOAD, RESET procedure;
- the parameters cannot be downloaded if the source controller and the target controller have incompatible firmware;
- the parameters cannot be copied from driver A to driver B.

2.10 Display electrical connections (display)

To display the probe and valve electrical connections for drivers A and B, enter display mode. See paragraph 3.4

2.11 General connection diagram

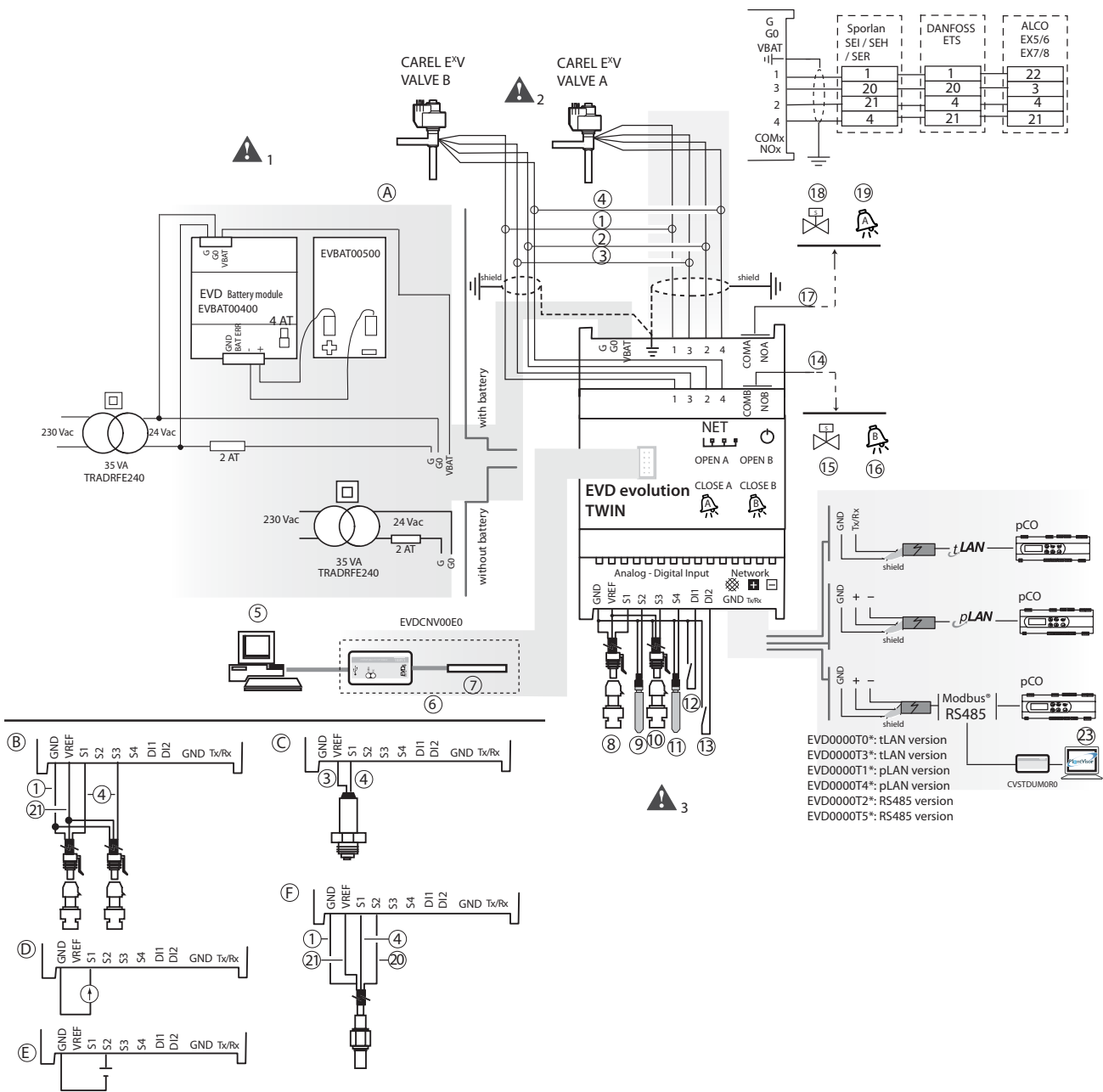

Fig. 2.m

Key:

1	green
2	yellow
3	brown
4	white
5	computer for configuration
6	USB/tLAN converter
7	adapter
8	ratiometric pressure transducer driver A
9	NTC probe driver A
10	ratiometric pressure transducer driver B
11	NTC probe driver B
12	digital input 1 configured to enable control driver A
13	digital input 2 configured to enable control driver B
14	voltage-free contact (up to 230 Vac) driver B
15	solenoid valve driver B
16	alarm signal driver B
17	voltage-free contact (up to 230 Vac) driver A
18	solenoid valve driver A
19	alarm signal driver A
20	red

21	black
22	blue
23	computer for configuration/supervision
A	Connection to EVBAT00400/EVABAT00500
B	Connection to ratiometric pressure transducer (SPKT00**R0)
C	Connection to electronic pressure probe (SPK**0000) or piezoresistive pressure transducer (SPKT00*C00)
D	Connection as positioner (4 to 20 mA input)
E	Connection as positioner (0 to 10 Vdc input)
F	Connection to combined pressure/temperature probe (SPKP00**T0)
⚠ 1	The maximum length of the connection cable to the EVBAT00400 module is 5 m.
⚠ 2	The connection cable to the valve motor must be 4-wire shielded, AWG 22 Lmax= 10 m or AWG14 Lmax= 50 m.
⚠ 3	connect all the shields of the probe cables to the earth spade

3. USER INTERFACE

The user interface consists of 8 LEDs that display the operating status, as shown in the table:

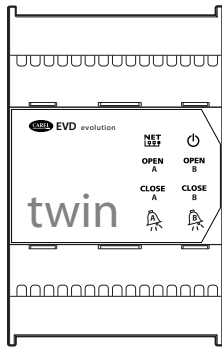

Fig. 3.a

Key:

LED	On	Off	Flashing
NET	Connection active	No connection	Communication error
OPEN A/B	Opening valve A/B	-	Driver A/B disabled (*)
CLOSE A/B	Closing valve A/B	-	Driver A/B disabled (*)
	Active alarm driver A/B	-	-
	Controller powered	Controller off	Wrong power supply (see chap. on Alarms)

Tab. 3.a

(*) Awaiting completion of the initial configuration

3.1 Assembling the display board (accessory)

The display board, once installed, is used to perform all the configuration and programming operations on the two drivers. It displays the operating status, the significant values for the type of control that the drivers are performing (e.g. superheat control), the alarms, the status of the digital inputs and the relay outputs. Finally, it can save the configuration parameters for one controller and transfer them to a second controller (see the procedure for uploading and downloading the parameters).

For installation:

- remove the cover, pressing on the fastening points;
- fit the display board, as shown;
- the display will come on, and if the controller is being commissioned, the guided configuration procedure will start.

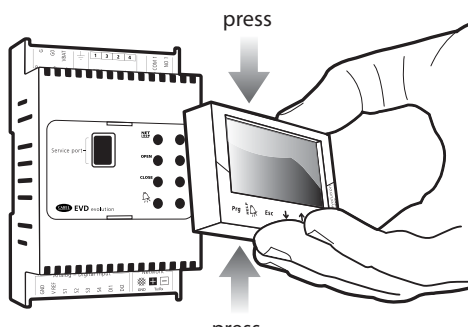

Fig. 3.b

Important: the controller is not activated if the configuration procedure has not been completed.

The front panel now holds the display and the keypad, made up of 6 buttons, that, pressed alone or in combination, are used to perform all the configuration and programming operations on the controller.

3.2 Display and keypad

The graphic display shows two variables for each driver (A, B), the control status of the driver, activation of the protectors, any alarms and the status of the relay output.

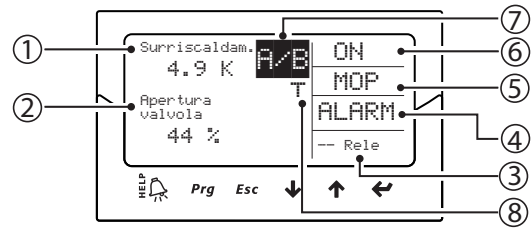

Fig. 3.c

Key:

1	variable 1 on the display (driver A/B)
2	variable 2 on the display (driver A/B)
3	relay status (driver A/B)
4	alarm (press "HELP")
5	protector activated
6	control status
7	current display: driver A/driver B
8	adaptive control in progress

Messages on the display

	Control status		Active protection
ON	Operation	LowSH	Low superheat
OFF	Standby	LOP	Low evaporation temperature
POS	Positioning	MOP	High evaporation temperature
WAIT	Wait		
CLOSE	Closing		
INIT	Valve motor error recognition procedure (*)		
TUN	Tuning in progress		

Tab. 3.b

(*) The valve motor error recognition procedure can be disabled. See paragraph 9.5.

Keypad

Button	Function
Prg	• opens the screen for entering the password to access programming mode.
	• if in alarm status, displays the alarm queue; • in the "Manufacturer" level, when scrolling the parameters, shows the explanation screens (Help); • pressed together with ENTER, switches the display from one driver to the other
Esc	• exits the Programming (Service/Manufacturer) and Display modes; • after setting a parameter, exits without saving the changes.
↓ / ↑	• navigates the screens on the display; • increases/decreases the value.
UP/DOWN	
	• switches from display to parameter programming mode;
ENTER	• confirms the value and returns to the list of parameters; • pressed together with HELP, switches the display from one driver to the other.

Tab. 3.c

Note: the variables displayed as standard can be selected by configuring the parameters "Variable 1 on display" and "Variable 2 on display" for each driver. See the list of parameters.

3.3 Switching between drivers (display)

Procedure:

press the Help and Enter buttons together. Switching when programming the parameters displays the parameters for driver A and driver B on the same screen.

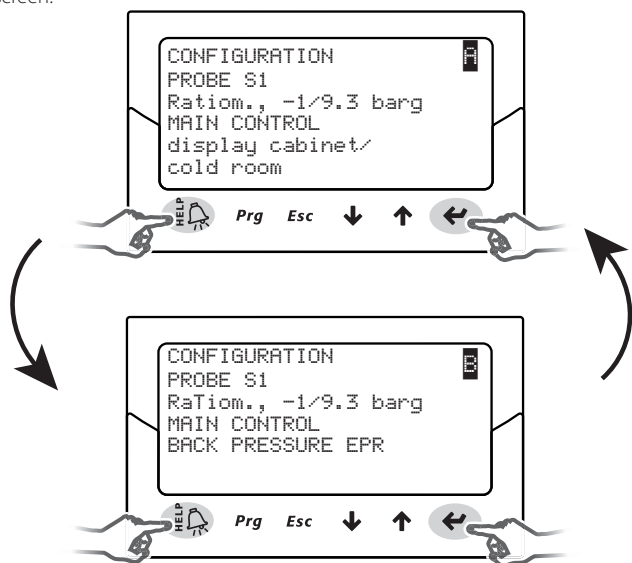

Fig. 3.d

Important: the probe S1 parameter is common to both drivers, while the main control parameter must be set for each driver. See the table of parameters.

3.4 Display mode (display)

Display mode is used to display the useful variables showing the operation of the system.

The variables displayed depend on the type of control selected.

1. Press Esc one or more times to switch to the standard display;
2. Select driver A or B to display the corresponding variables (see paragraph 3.3);
3. press UP/DOWN: the display shows a graph of the superheat, the percentage of valve opening, the evaporation pressure and temperature and the suction temperature variables;
4. press UP/DOWN: the variables are shown on the display followed by the screens with the probe and valve motor electrical connections;
5. press Esc to exit display mode.

For the complete list of variables used according to the type of control see paragraph 8.6.

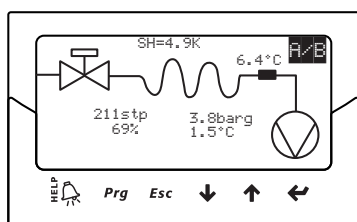

Fig. 3.e

3.5 Programming mode (display)

The parameters can be modified using the front keypad. Access differs according to the user level: Service (Installer) and Manufacturer parameters.

Modifying the Service parameters

The Service parameters, as well as the parameters for commissioning the controller, also include those for the configuration of the inputs, the relay output, the superheat set point or the type of control in general, and the protection thresholds. See the table of parameters.

Procedure:

1. press Esc one or more times to switch to the standard display and select driver A or B to set the corresponding parameters (see paragraph 3.3);
2. press Prg: the display shows a screen with the PASSWORD request;

3. press ENTER and enter the **password for the Service level: 22**, starting from the right-most figure and confirming each figure with ENTER;
4. if the value entered is correct, the first modifiable parameter is displayed, network address;
5. press UP/DOWN to select the parameter to be set;
6. press ENTER to move to the value of the parameter;
7. press UP/DOWN to modify the value;
8. press ENTER to save the new value of the parameter;
9. repeat steps 5, 6, 7, 8 to modify the other parameters;
10. press Esc to exit the procedure for modifying the Service parameters.

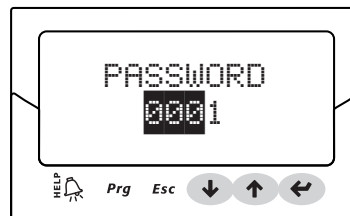

Fig. 3.f

Important:

- if when setting a parameter the value entered is out-of-range, this is not accepted and the parameter soon after returns to the previous value;
- if no button is pressed, after 5 min the display automatically returns to the standard mode.
- to set a negative value use ENTER to move to the left-most digit and press UP/DOWN.

Modifying the Manufacturer parameters

The Manufacturer level is used to configure all the controller parameters, and consequently, in addition to the Service parameters, the parameters relating to alarm management, the probes and the configuration of the valve. See the table of parameters.

Procedure:

1. press Esc one or more times to switch to the standard display;
2. Select driver A or B to set the corresponding parameters (see paragraph 3.3);
3. press Prg: the display shows a screen with the PASSWORD request;
4. press ENTER and enter the **password for the Manufacturer level: 66**, starting from the right-most figure and confirming each figure with ENTER;
5. if the value entered is correct, the list of parameter categories is shown:
 - Configuration
 - Probes
 - Control
 - Special
 - Alarm configuration
 - Valve
6. press the UP/DOWN buttons to select the category and ENTER to access the first parameter in the category;
7. press UP/DOWN to select the parameter to be set and ENTER to move to the value of the parameter;
8. press UP/DOWN to modify the value;
9. press ENTER to save the new value of the parameter;
10. repeat steps 7, 8, 9 to modify the other parameters;
11. press Esc to exit the procedure for modifying the Manufacturer parameters

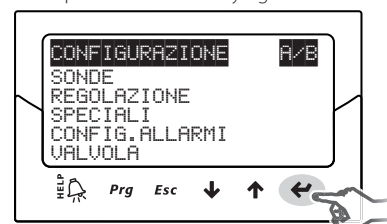

Fig. 3.g

Important:

- all the controller parameters can be modified by entering the Manufacturer level;
- if when setting a parameter the value entered is out-of-range, this is not accepted and the parameter soon after returns to the previous value;
- if no button is pressed, after 5 min the display automatically returns to the standard mode.

4. COMMISSIONING

4.1 Commissioning

Once the electrical connections have been completed (see the chapter on installation) and the power supply has been connected, the operations required for commissioning the controller depend on the type of interface used, however essentially involve setting just 4 parameters: refrigerant, valve, type of pressure probe (S1 for driver A and S3 for driver B) and type of main control. The network address for EVD evolution twin is single.

Types of interfaces:

- **DISPLAY:** after having correctly configured the setup parameters, confirmation will be requested. Only after confirmation will the controller be enabled for operation, the main screen will be shown on the display and control will be able to commence when requested by the pCO controller via LAN or when digital input DI1 closes for driver A and DI2 for driver B. See paragraph 4.2;
- **VPM:** to enable control of the drivers via VPM, set "Enable EVD control" to 1; this is included in the safety parameters, in the special parameters menu, under the corresponding access level. However, the setup parameters should first be set in the related menu. The drivers will then be enabled for operation and control will be able to commence when requested by the pCO controller via LAN or when digital input DI1/DI2 closes. If due to error or for any other reason "Enable EVD control" should be set to 0 (zero), the controller will immediately stop control and will remain in standby until re-enabled, with the valve stopped in the last position;
- **SUPERVISOR:** to simplify the commissioning of a considerable number of controllers using the supervisor, the setup operation on the display can be limited to simply setting the network address. The display will then be able to be removed and the configuration procedure postponed to a later stage using the supervisor or, if necessary, reconnecting the display. To enable control of the controller via supervisor, set "Enable EVD control"; this is included in the safety parameters, in the special parameters menu, under the corresponding access level. However, the setup parameters should first be set in the related menu. The controller will then be enabled for operation and control will be able to commence when requested by the pCO controller via pLAN or when digital input DI1 closes for driver A and DI2 for driver B. As highlighted on the supervisor, inside of the yellow information field relating to the "Enable EVD control" parameter, if due to error or for any other reason "Enable EVD control" should be set to 0 (zero), the controller will immediately stop control and will remain in standby until re-enabled, with the valve stopped in the last position;
- **pCO PROGRAMMABLE CONTROLLER:** the first operation to be performed, if necessary, is to set the network address using the display. If a pLAN, tLAN or Modbus® controller is used, connected to a pCO family controller, the setup parameters will not need to be set and confirmed. In fact, the application running on the pCO will manage the correct values based on the unit controlled. Consequently, simply set the pLAN, tLAN or Modbus® address for the controller as required by the application on the pCO, and after a few seconds communication will commence between the two instruments and the controller automatically be enabled for control. The main screen will shown on the display, which can then be removed, and control will be able to commence when requested by the pCO controller or digital input DI1 for driver A and DI2 for driver B. (see paragraph 6.3). If there is no communication between the pCO and the controller (see the paragraph "LAN error alarm"), this will be able to continue control based on the status of the digital inputs.

4.2 Guided commissioning procedure (display)

After having fitted the display:

- the first parameter is displayed: network address;
- press Enter to move to the value of the parameter
- press UP/DOWN to modify the value
- press Enter to confirm the value
- press UP/DOWN to move to the next parameter, refrigerant for driver A, indicated by the letter at the top right;
- repeat steps 2, 3, 4, 5 to modify the values of the parameters for driver A: refrigerant, valve, pressure probe S1, main control;
- check that the probe electrical connections are correct for driver A;
- check that the electrical connections are correct for valve A; then set the same parameters for driver B (see step 6);
- set the values of the parameters for driver B: refrigerant, valve B, pressure probe S3, main control;
- check that the probe electrical connections are correct for driver B;
- check that the electrical connections are correct for valve B;
- if the configuration is correct exit the procedure, otherwise choose NO and return to step 2.

At the end of the configuration procedure the controller activates the valve motor error recognition procedure, displaying "INIT" on the display. See paragraph 9.5. To simplify commissioning and avoid possible malfunctions, the controller will not start until the following have been configured for each driver:

1. network address (common parameter);
2. refrigerant;
3. valve;
4. pressure probe;
5. type of main control, that is, the type of unit the superheat control is applied to.



Note:

- to exit the guided commissioning procedure press the DOWN button repeatedly and finally confirm that configuration has been completed. The guided procedure CANNOT be ended by pressing Esc;
- if the configuration procedure ends with a configuration error, access Service parameter programming mode and modify the value of the parameter in question;
- if the valve and/or the pressure probe used are not available in the list, select any model and end the procedure. Then the controller will be enabled for control, and it will be possible to enter Manufacturer programming mode and set the corresponding parameters manually. Below are the parameters for driver A and driver B to be set during the commissioning procedure. **These parameters have the same description for both driver A and driver B, the user can recognise which parameter is being set by the letter A/B shown at the top right of the display.**



Important:

for 24 Vdc power supply, at the end of the guided commissioning procedure, to start control set "Power supply mode" parameter=1, otherwise the valves remain in the closed position. See paragraph 6.1.

Network address

The network address assigns to the controller an address for the serial connection to a supervisory system via RS485, and to a pCO controller via pLAN, tLAN, Modbus®. This parameter is common to both drivers A and B.

Parameter/description	Def.	Min.	Max.	UOM
CONFIGURATION				
Network address	198	1	207	-

Tab. 4.a

For network connection of the RS485/Modbus® models the communication speed also needs to be set, in bits per second, using the parameter "Network settings". See paragraph 6.1

Refrigerant

The type of refrigerant is essential for calculating the superheat. In addition, it is used to calculate the evaporation and condensing temperature based on the reading of the pressure probe.

Parameter/description	Def.
CONFIGURATION	
Refrigerant	R404A
1=R22; 2=R134a; 3=R404A; 4=R407C; 5=R410A; 6=R507A; 7=R290; 8=R600; 9=R600a; 10=R717; 11=R744; 12=R728; 13=R1270; 14=R417A; 15=R422D; 16=R413A; 17=R422A; 18=R423A; 19=R407A; 20=R427A; 21=R245Fa; 22=R407F	

Tab. 4.b

Valve

Setting the type of valve automatically defines all the control parameters based on the manufacturer's data for each model. In Manufacturer programming mode, the control parameters can then be fully customised if the valve used is not in the standard list. In this case, the controller will detect the modification and indicate the type of valve as "Customised".

Parameter/description	Def.
CONFIGURATION	
Valve:	CAREL EXV
1= CAREL EXV; 2= Alco EX4; 3=Alco EX5; 4=Alco EX6; 5=Alco EX7; 6=Alco EX8 330 Hz recommended CAREL; 7=Alco EX8 500 Hz specific Alco; 8=Sporlan SEI 0.5-11; 9=Sporlan SER 1.5-20; 10=Sporlan SEI 30; 11=Sporlan SEI 50; 12=Sporlan SEH 100; 13=Sporlan SEH 175; 14=Danfoss ETS 12.5-25B; 15=Danfoss ETS 50B; 16=Danfoss ETS 100B; 17=Danfoss ETS 250; 18=Danfoss ETS 400; 19=Two EXV CAREL connected together; 20=Sporlan SER(I)G,J,K; 21= Danfoss CCM 10-20-30; 22= Danfoss CCM 40	E°V

Tab. 4.c



Important:

- two CAREL EXV valves connected together must be selected if two CAREL EXV valves are connected to the same terminal, to have parallel or complementary operation;
- as described, control is only possible with CAREL EXV valves;
- NOT all CAREL valves can be connected: see paragraph 2.5.

Pressure probes S1 & S3

Setting the type of pressure probe S1 for driver A and S3 for driver B defines the range of measurement and the alarm limits based on the manufacturer's data for each model, usually indicated on the rating plate on the probe.

Parameter/description	Def.
CONFIGURATION	
Probe S1, S3	Ratiom.: -1 to 9.3 barg
Ratiometric (OUT= 0 to 5 V)	Electronic (OUT= 4 to 20 mA)
1= -1 to 4.2 barg	8= -0.5 to 7 barg
2= 0.4 to 9.3 barg	9= 0 to 10 barg
3= -1 to 9.3 barg	10= 0 to 18.2 barg
4= 0 to 17.3 barg	11= 0 to 25 barg
5= 0.85 to 34.2 barg	12= 0 to 30 barg
6= 0 to 34.5 barg	13= 0 to 44.8 barg
7= 0 to 45 barg	14= remote, -0.5 to 7 barg
	15= remote, 0 to 10 barg
	16= remote, 0 to 18.2 barg
	17= remote, 0 to 25 barg
	18= remote, 0 to 30 barg
	19= remote, 0 to 44.8 barg
	20= External signal (4 to 20 mA)
21= -1 to 12.8 barg	
22= 0 to 20.7 barg	
23= 1.86 to 43.0 barg	

Tab. 4.d



Important:

if two pressure probes S1 and S3 are installed, these must be the same type. A ratiometric probe and an electronic probe cannot be used together.



Note:

in the case of multiplexed systems where the same pressure probe is shared between the twin1 and twin2 controllers, choose the normal option for driver A and the "remote" option for the remaining drivers. Example: to use the same pressure probe P1 for driver A and B: 4 to 20 mA, -0.5 to 7 barg
 For driver A on the twin 1 controller select: 4 to 20 mA, -0.5 to 7 barg.
 For driver B on the twin 1 controller and for driver A and B on the twin 2 controller select: remote 4 to 20 mA, -0.5 to 7 barg.
 The connection diagram is shown in paragraph 2.6



Note:

- the range of measurement by default is always in bar gauge (barg). In the manufacturer menu, the parameters corresponding to the range of measurement and the alarms can be customised if the probe used is not in the standard list. If modifying the range of measurement, the controller will detect the modification and indicate the type of probe S1 or S3 as "Customised";
- the software on the controller takes into consideration the unit of measure. If a range of measurement is selected and then the unit of measure is changed (from bars to psi), the controller automatically updates the limits of the range of measurement and the alarm limits. By default, the main control probes S2 and S4 are set as "CAREL NTC". Other types of probes can be selected in the service menu;
- unlike the pressure probes, the temperature probes do not have any modifiable parameters relating to the range of measurement, and consequently only the models indicated in the list can be used (see the chapter on "Functions" and the list of parameters). In any case, in manufacturer programming mode, the limits for the probe alarm signal can be customised.

Main control

Setting the main control defines the operating mode for each driver.

Parameter/description	Def.
CONFIGURATION	
Main control	
Superheat control	
1= multiplexed showcase/cold room	multiplexed showcase/ cold room
2= showcase/cold room with compressor on board	
3= "perturbed" showcase/cold room	
4= showcase/cold room with sub-critical CO ₂	
5= R404A condenser for sub-critical CO ₂	
6= air-conditioner/chiller with plate heat exchanger	
7= air-conditioner/chiller with tube bundle heat exchanger	
8= air-conditioner/chiller with finned coil heat exchanger	
9= air-conditioner/chiller with variable cooling capacity	
10= "perturbed" air-conditioner/chiller	
Special control	
11= EPR back pressure	
12= hot gas bypass by pressure	
13= hot gas bypass by temperature	
14= transcritical CO ₂ gas cooler	
15= analogue positioner (4 to 20 mA)	
16= analogue positioner (0 to 10 V)	
17= air-conditioner/chiller or showcase/cold room with adaptive control	
18= air-conditioner/chiller with Digital Scroll compressor	
19= AC/chiller with SIAM ANB scroll compressor	
(CANNOT BE SELECTED)	
20= superheat regulation with 2 temperature probes (CANNOT BE SELECTED)	
21= I/O expander for pCO	

(*) only for CAREL valves controls

Tab. 4.e

The superheat set point and all the parameters corresponding to PID control, the operation of the protectors and the meaning and use of probes S1/S3 and/or S2/S4 will be automatically set to the values recommended by CAREL based on the selected application.

During this initial configuration phase, only superheat control mode from 1 to 10 can be set, which differ based on the application (chiller, refrigerated cabinet, etc.).

In the event of errors in the initial configuration, these parameters can later be accessed and modified inside the service or manufacturer menu.

If the controller default parameters are restored (RESET procedure, see the chapter on Installation), when next started the display will again show the guided commissioning procedure.

4.3 Checks after commissioning

After commissioning:

- check that the valves complete a full closing cycle to perform alignment;
- set, if necessary, in Service or Manufacturer programming mode, the superheat set point (otherwise keep the value recommended by CAREL based on the application) and the protection thresholds (LOP, MOP, etc.). See the chapter on Protectors.

4.4 Other functions

By entering Service programming mode, other types of main control can be selected (transcritical CO₂, hot gas bypass, etc.), as well as so-called special control functions, and suitable values set for the control set point and the LowSH, LOP and MOP protection thresholds (see the chapter on "Protectors"), which depend on the specific characteristics of the unit controlled.

By entering Manufacturer programming mode, finally, the operation of the controller can be completely customised, setting the function of each parameter. If the parameters corresponding to PID control are modified, the controller will detect the modification and indicate the main control as "Customised".

5. CONTROL

5.1 Main control

EVD evolution twin features two types of control, which can be set independently for driver A and B.

Main control defines the operating mode of the driver. The first 10 settings refer to superheat control, the others are so-called "special" settings and are pressure or temperature settings or depend on a control signal from an external controller. The two last special functions also relate to superheat control.

Parameter/Description	Def.
CONFIGURATION	
Main control	multiplexed showcase/cold room
Superheat control	
1= multiplexed showcase/cold room	showcase/cold room
2= showcase/cold room with compressor on board	
3= "perturbed" showcase/cold room	
4= showcase/cold room with sub-critical CO ₂	
5= R404A condenser for sub-critical CO ₂	
6= air-conditioner/chiller with plate heat exchanger	
7= air-conditioner/chiller with tube bundle heat exchanger	
8= air-conditioner/chiller with finned coil heat exchanger	
9= air-conditioner/chiller with variable cooling capacity	
10= "perturbed" air-conditioner/chiller	
Special control	
11= EPR back pressure	
12= hot gas bypass by pressure	
13= hot gas bypass by temperature	
14= transcritical CO ₂ gas cooler	
15= analogue positioner (4 to 20 mA)	
16= analogue positioner (0 to 10 V)	
17= air-conditioner/chiller or showcase/cold room with adaptive control	
18= air-conditioner/chiller with Digital Scroll compressor	
19= AC/chiller with SIAM ANB scroll compressor (CANNOT BE SELECTED)	
20= superheat regulation with 2 temperature probes (CANNOT BE SELECTED)	
21= I/O expander for pCO ^(*)	

(*) only for CAREL valve drivers

(**) control only settable on driver A, however corresponds to the entire controller.

Tab. 5.f

Note:

- R404A condensers with subcritical CO₂ refer to superheat control for valves installed in cascading systems where the flow of R404A (or other refrigerant) in an exchanger acting as the CO₂ condenser needs to be controlled;
- "perturbed" cabinet/cold room or air-conditioner/chiller refer to units that momentarily or permanently operate with swinging condensing or evaporation pressure.

The following paragraphs explain all the types of control that can be set on EVD evolution twin.

5.2 Superheat control

The primary purpose of the electronic valve is ensure that the flow-rate of refrigerant that flows through the nozzle corresponds to the flow-rate required by the compressor. In this way, the evaporation process will take place along the entire length of the evaporator and there will be no liquid at the outlet and consequently in the branch that runs to the compressor.

As liquid is not compressible, it may cause damage to the compressor and even breakage if the quantity is considerable and the situation lasts some time.

Superheat control

The parameter that the control of the electronic valve is based on is the superheat temperature, which effectively tells whether or not there is liquid at the end of the evaporator. EVD Evolution twin can independently manage superheat control on two refrigerant circuits.

The superheat temperature is calculated as the difference between: superheated gas temperature (measured by a temperature probe located at the end of the evaporator) and the saturated evaporation temperature (calculated based on the reading of a pressure transducer located at the end of the evaporator and using the Tsat(P) conversion curve for each refrigerant). Superheat = Superheated gas temperature(*) - Saturated evaporation temperature

(*) suction

If the superheat temperature is high it means that the evaporation process is completed well before the end of the evaporator, and therefore flow-rate of refrigerant through the valve is insufficient. This causes a reduction in cooling efficiency due to the failure to exploit part of the evaporator. The valve must therefore be opened further. Vice-versa, if the superheat temperature is low it means that the evaporation process has not concluded at the end of the evaporator and a certain quantity of liquid will still be present at the inlet to the compressor.

The valve must therefore be closed further. The operating range of the superheat temperature is limited at the lower end: if the flow-rate through the valve is excessive the superheat measured will be near 0 K. This indicates the presence of liquid, even if the percentage of this relative to the gas cannot be quantified.

There is therefore an undetermined risk to the compressor that must be avoided. Moreover, a high superheat temperature as mentioned corresponds to an insufficient flow-rate of refrigerant.

The superheat temperature must therefore always be greater than 0 K and have a minimum stable value allowed by the valve-unit system.

A low superheat temperature in fact corresponds to a situation of probable instability due to the turbulent evaporation process approaching the measurement point of the probes.

The expansion valve must therefore be controlled with extreme precision and a reaction capacity around the superheat set point, which will almost always vary from 3 to 14 K.

Set point values outside of this range are quite infrequent and relate to special applications.

Example of superheat control on two independent circuits A and B.

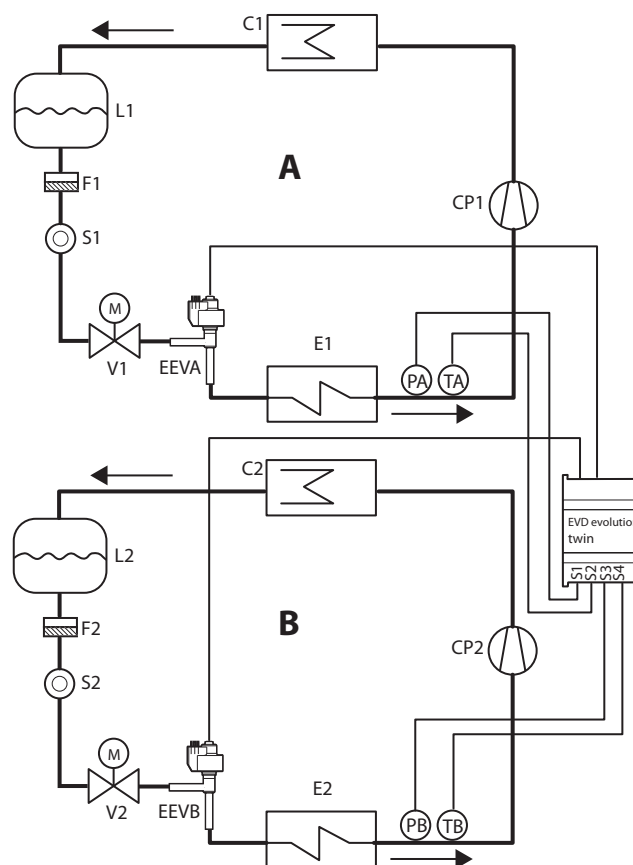

Fig. 5.a

Key:

CP1, CP2	compressor 1,2
C1, C2	condenser 1, 2
L1, L2	liquid receiver 1, 2
F1, F2	dewatering filter 1, 2
S1, S2	liquid indicator 1, 2
EEVA, EEVB	electronic expansion valve A,B
V1, V2	solenoid valve 1, 2
E1, E2	evaporator 1, 2
PA, PB	pressure probe
TA, TB	temperature probe

For the wiring, see paragraph 2.11 "General connection diagram".

Another application involves superheat control of two evaporators in the same circuit.

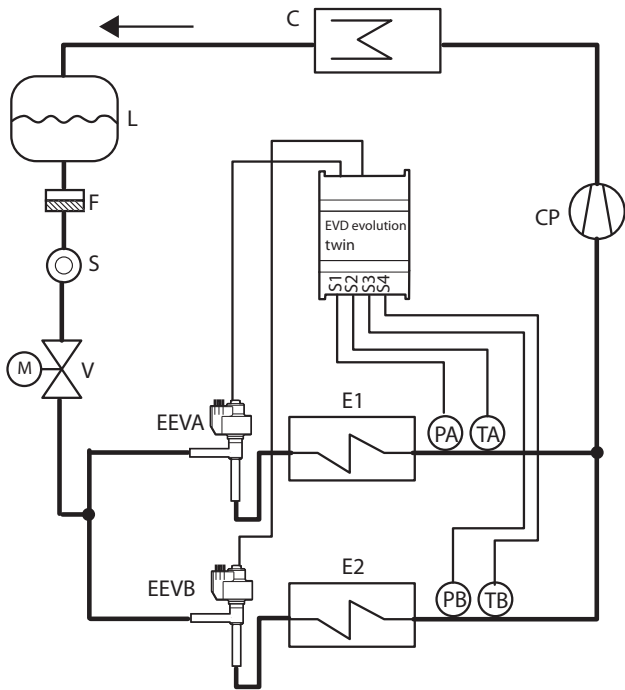

Fig. 5.b

Key:

CP	compressor
C	condenser
L	liquid receiver
F	dewatering filter
S	liquid indicator
EEVA,	electronic expansion valve A
EEVB	electronic expansion valve B
E1, E2	evaporator 1, 2
PA, PB	pressure probe driver A, B
TA, TB	temperature probe driver A, B
V	solenoid valve

For the wiring, see paragraph 2.11 "General connection diagram".

Nota: in this example only one electronic pressure transducer with 4 to 20 mA output (SPK**0000) can be used, shared between driver A and B. Ratiometric transducers cannot be shared.

Another possibility involves connecting two equal valves (operation in parallel mode, see paragraph 2.5) to the same evaporator. This is useful in reverse-cycle chiller/heat pump applications, to improve distribution of the refrigerant in the outdoor coil.

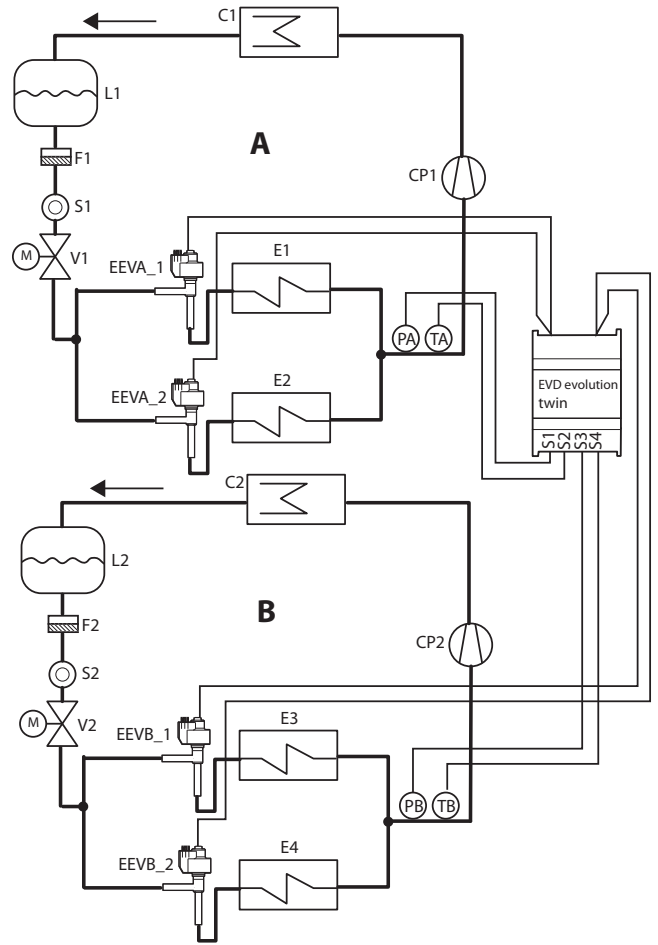

Fig. 5.c

Key:

CP1,2	compressor 1, 2
C1,C2	condenser 1, 2
E1, E2, E3, E4	evaporator 1, 2, 3, 4
F1, F2	dewatering filter 1, 2
S1, S2	liquid indicator 1, 2
EEVA_1,	electronic expansion valves driver A
EEVA_2	
EEVB_1,	electronic expansion valves driver B
EEVB_2	
TA, TB	temperature probe
L1, L2	liquid receiver 1, 2
V1, V2	solenoid valve 1, 2

For the wiring, see paragraph 2.11 "General connection diagram".

PID parameters

Superheat control, as for any other mode that can be selected with the "main control" parameter, is performed using PID control, which in its simplest form is defined by the law:

$$u(t) = K \left(e(t) + \frac{1}{T_i} \int e(t) dt + T_d \frac{de(t)}{dt} \right)$$

Key:

u(t)	Valve position	Ti	Integral time
e(t)	Error	Td	Derivative time
K	Proportional gain		

Note that control is calculated as the sum of three separate contributions: proportional, integral and derivative.

- the proportional action opens or closes the valve proportionally to the variation in the superheat temperature. Thus the greater the K (**proportional gain**) the higher the response speed of the valve. The proportional action does not consider the superheat set point, but rather only reacts to variations. Therefore if the superheat value does not vary significantly, the valve will essentially remain stationary and the set point cannot be reached;
- the integral action is linked to time and moves the valve in proportion to the deviation of the superheat value from the set point. The greater the deviations, the more intense the integral action; in addition, the lower the value of T (**integral time**), the more intense the action will be. The integration time, in summary, represents the intensity of the reaction of the valve, especially when the superheat value is not near the set point;
- the derivative action is linked to the speed of variation of the superheat value, that is, the gradient at which the superheat changes from instant to instant. It tends to react to any sudden variations, bringing forward the corrective action, and its intensity depends on the value of the time T (**derivative time**).

Parameter/Description	Def.	Min.	Max.	UOM
CONTROL				
Superheat set point	11	LowSH: threshold	180 (324)	K(°F)
PID: proportional gain	15	0	800	-
PID: integral time	150	0	1000	s
PID: derivative time	5	0	800	s

Tab. 5.g

See the "EEV system guide" +030220810 for further information on calibrating PID control.

Note: when selecting the type of main control (both superheat control and special modes), the PID control values suggested by CAREL will be automatically set for each application.

Protection function control parameters

See the chapter on "Protectors". Note that the protection thresholds are set by the installer/manufacturer, while the times are automatically set based on the PID control values suggested by CAREL for each application.

Parameter/Description	Def.	Min.	Max.	UOM
CONTROL				
LowSH protection: threshold	5	-40 (-72)	SH set point	K(°F)
LowSH protection: integral time	15	0	800	s
LOP protection: threshold	-50	-60 (-76)	MOP: threshold	°C (°F)
LOP protection: integral time	0	0	800	s
MOP protection: threshold	50	LOP: threshold	200 (392)	°C (°F)
MOP protection: integral time	20	0	800	s

Tab. 5.h

5.3 Adaptive control and autotuning

EVD evolution TWIN features two functions used to automatically optimise the PID parameters for superheat control, useful in applications where there are frequent variations in thermal load:

1. automatic adaptive control: the function continuously evaluates the effectiveness of superheat control and activates one or more optimisation procedures accordingly;
2. manual autotuning: this is activated by the user and involves just one optimisation procedure.

Both procedures give new values to the PID superheat control and protection function parameters:

- PID: proportional gain;
- PID: integral time;
- PID: derivative time;
- LowSH: low superheat integral time;
- LOP: low evaporation temperature integral time;
- MOP: high evaporation temperature integral time.

Given the highly variable dynamics of superheat control on different units, applications and valves, the theories on stability that adaptive control and autotuning are based on are not always definitive. As a consequence, the following procedure is suggested, in which each successive step is performed if the previous has not given a positive outcome:

1. use the parameters recommended by CAREL to control the different units based on the values available for the "Main control" parameter;
2. use any parameters tested and calibrated manually based on laboratory or field experiences with the unit in question;
3. enable automatic adaptive control;
4. activate one or more manual autotuning procedures with the unit in stable operating conditions if adaptive control generates the "Adaptive control ineffective" alarm.

Adaptive control

After having completed the commissioning procedure, to activate adaptive control, set the parameter:

"Main control"= air-conditioner/chiller or showcase/cold room with adaptive control

Parameter/Description	Def.
CONFIGURATION	
Main control	multiplexed showcase/cold room
...	
air-conditioner/chiller or showcase/cold room with adaptive control	

Tab. 5.i

The activation status of the tuning procedure will be shown on the standard display by the letter "T".

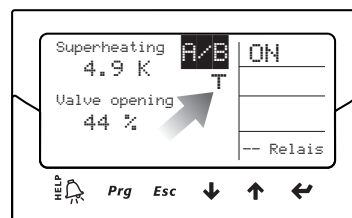

Fig. 5.d

With adaptive control enabled, the controller constantly evaluates whether control is sufficiently stable and reactive; otherwise the procedure for optimising the PID parameters is activated. The activation status of the optimisation function is indicated on the standard display by the message "TUN" at the top right.

The PID parameter optimisation phase involves several operations on the valve and readings of the control variables so as to calculate and validate the PID parameters. These procedures are repeated to fine-tune superheat control as much as possible, over a maximum of 12 hours.

Note:

- during the optimisation phase maintenance of the superheat set point is not guaranteed, however the safety of the unit is ensured through activation of the protectors. If these are activated, the procedure is interrupted;
- if all the attempts performed over 12 hours are unsuccessful, the "adaptive control ineffective" alarm will be signalled and adaptive control will be disabled, resetting the default values of the PID and protection function parameters;
- to deactivate the "adaptive control ineffective" alarm set the value of the "main control" parameter to one of the first 10 options. If required, adaptive control can be immediately re-enabled using the same parameter. If the procedure ends successfully, the resulting control parameters will be automatically saved.

Autotuning

EVD evolution TWIN also features an automatic tuning function (Autotuning) for the superheat and protector control parameters, which can be started by setting the parameter "Force manual tuning" = 1.

Parameter/Description	Def.	Min.	Max.	UOM
SPECIAL				
Force manual tuning	0	0	1	-
0 = no; 1 = yes				

Tab. 5.j

The activation status of the procedure is indicated on the standard display by the message "TUN" at the top right.

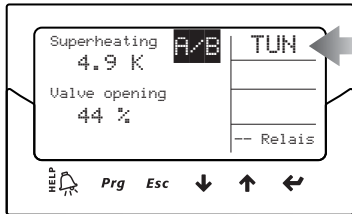

Fig. 5.e

The optimisation procedure can only be performed if the driver is in control status, and lasts from 10 to 40 minutes, performing specific movements of the valve and measurements of the control variables.

Note:

- during the function maintenance of the superheat set point is not guaranteed, however the safety of the unit is ensured through activation of the protectors. If these are activated, the procedure is interrupted;
- if, due to external disturbance or in the case of particularly unstable systems, the procedure cannot suitably optimise the parameters, the controller will continue using the parameters saved in the memory before the procedure was started. If the procedure ends successfully, the resulting control parameters will be automatically saved.
- both the tuning procedure and adaptive control can only be enabled for superheat control, they cannot be used for the special control functions

For CAREL internal use only, some tuning procedure control parameters can be shown on the display, supervisor, pCO and VPM; these must not be modified by non-expert users.

These are:

- Tuning method
- Adaptive control status
- Last tuning result

Parameter/Description	Def.	Min.	Max.	UOM
SPECIAL				
Tuning method	0	0	255	-

Tab. 5.k

Tuning method is visible as a parameter in the Special category, the two other parameters are visible in display mode. See paragraph 3.4.

Note:

the "Tuning method" parameter is for use by qualified CAREL technical personnel only and must not be modified.

5.4 Control with Emerson Climate Digital Scroll™ compressor



Important: this type of control is incompatible with autotuning. Digital Scroll compressors allow wide modulation of cooling capacity by using a solenoid valve to active a patented refrigerant bypass mechanism. This operation nonetheless causes swings in the pressure of the unit, which may be amplified by normal control of the expansion valve, leading to malfunctions. Dedicated control ensures greater stability and efficiency of the entire unit by controlling the valve and limiting swings based on the instant compressor modulation status. To be able to use this mode, the LAN version driver must be connected to a Carel pCO series controller running a special application to manage units with Digital scroll compressors.

Parameter/Description	Def.
CONFIGURATION	
Main control	multiplexed showcase/cold room
...	
air-conditioner/chiller with Digital Scroll compressor	

Tab. 5.l

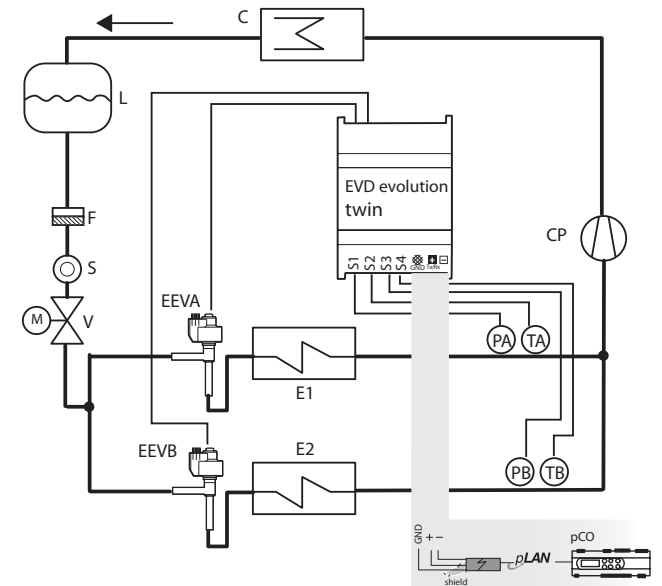

Fig. 5.f

Key:

CP	Compressor	V	Solenoid valve
C	Condenser	S	Liquid gauge
L	Liquid receiver	EEV	Electronic expansion valve
F	Dewatering filter	E1, E2	Evaporator
TA, TB	Temperature probes	PA, PB	Pressure probes

For information on the wiring see paragraph 2.11 "General connection diagram".

5.5 Special control

EPR back pressure

This type of control can be used in applications in which a constant pressure is required in the refrigerant circuit. For example, a refrigeration system may include different showcases that operate at different temperatures (showcases for frozen foods, meat or dairy). The different temperatures of the circuits are achieved using pressure regulators installed in series with each circuit. The special EPR function (Evaporator Pressure Regulator) is used to set a pressure set point and the PID control parameters required to achieve this.

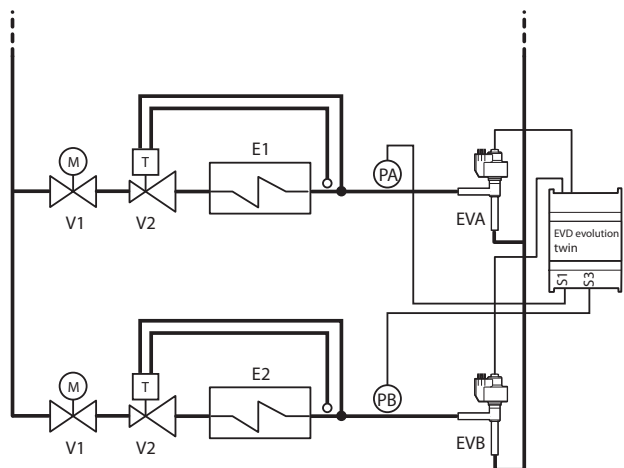

Fig. 5.g

Key:

V1	Solenoid valve	E1, E2	Evaporator 1, 2
V2	Thermostatic expansion valve	EVA, EVB	Electronic valve A, B
PA, PB	Pressure probe driver A, B		

For the wiring, see paragraph 2.11 "General connection diagram".

This involves PID control without any protectors (LowSH, LOP, MOP, see the chapter on Protectors), without any valve unblock procedure. Control is performed on the pressure probe value read by input S1 for driver A and S3 for driver B, compared to the set point: "EPR pressure set point". Control is direct, as the pressure increases, the valve opens and vice-versa.

Parameter/Description	Def.	Min.	Max.	UOM
CONTROL				
EPR pressure set point	3.5	-20 (-290)	200 (2900)	barg (psig)
PID: proportional gain	15	0	800	-
PID: integral time	150	0	1000	s
PID: derivative time	5	0	800	s

Tab. 5.m

Hot gas bypass by pressure

This control function can be used to control cooling capacity, which in the following example is performed by driver B. If there is no request from circuit Y, the compressor suction pressure decreases and the bypass valve opens to let a greater quantity of hot gas flow and decrease the capacity of circuit X. Driver A is used for superheat control on circuit Y.

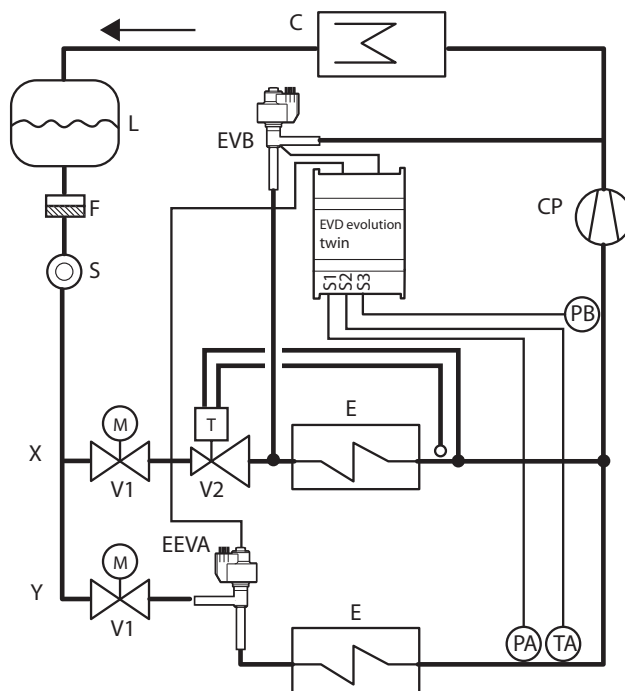

Fig. 5.h

Key:

CP	Compressor	V1	Solenoid valve
C	Condenser	V2	Thermostatic expansion valve
L	Liquid receiver	EEVA	Electronic expansion valve A
F	Dewatering filter	EVB	Electronic valve B
S	Liquid indicator	E	Evaporator

For the wiring, see paragraph 2.11 "General connection diagram".

This involves PID control without any protectors (LowSH, LOP, MOP, see the chapter on Protectors), without any valve unblock procedure. Control is performed on the hot gas bypass pressure probe value read by input S3, compared to the set point: "Hot gas bypass pressure set point". Control is reverse, as the pressure increases, the valve closes and vice-versa.

Parameter/Description	Def.	Min.	Max.	UOM
CONTROL				
Hot gas bypass pressure set point	3	-20 (290)	200 (2900)	barg (psig)
PID: proportional gain	15	0	800	-
PID: integral time	150	0	1000	s
PID: derivative time	5	0	800	s

Tab. 5.n

Hot gas bypass by temperature

This control function can be used to control cooling capacity, which in the following example is performed by driver B. On a refrigerated cabinet, if the ambient temperature probe S4 measures an increase in the temperature, the cooling capacity must also increase, and so the EVB valve must close. In the example driver A is used for superheat control.

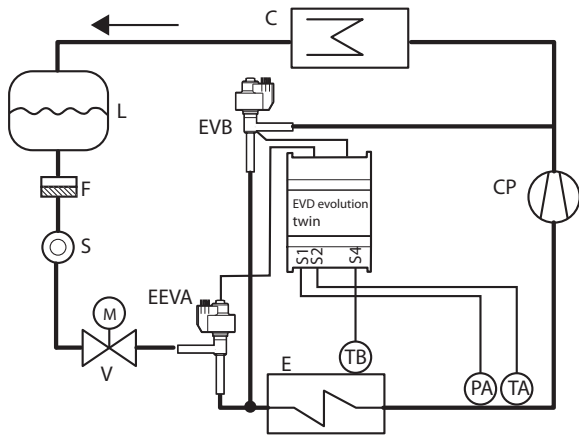

Fig. 5.i

Key:

CP	Compressor	V	Solenoid valve
C	Condenser	EEVA	Electronic expansion valve A
L	Liquid receiver	EVB	Electronic valve B
F	Dewatering filter	E	Evaporator
S	Liquid indicator	PA	Pressure probe driver A
TA, TB	Temperature probe		

For the wiring, see paragraph 2.11 "General connection diagram".

This involves PID control without any protectors (LowSH, LOP, MOP, see the chapter on Protectors), without any valve unblock procedure. Control is performed on the hot gas bypass temperature probe value read by input S4, compared to the set point: "Hot gas bypass temperature set point". Control is reverse, as the temperature increases, the valve closes.

Parameter/Description	Def.	Min.	Max.	UOM
CONTROL				
Hot gas bypass temperature set point	10	-60 (-76)	200 (392)	°C (°F)
PID: proportional gain	15	0	800	-
PID: integral time	150	0	1000	s
PID: derivative time	5	0	800	s

Tab. 5.o

Another application that exploits this control function uses the connection of two EXV valves together to simulate the effect of a three-way valve, called "reheating". To control humidity, valve EVB_2 is opened to let the refrigerant flow into exchanger S. At the same time, the air that flows through evaporator E is cooled and the excess humidity removed, yet the temperature is below the set room temperature. It then flows through exchanger S, which heats it back to the set point (reheating). In addition, if dehumidification needs to be increased, with less cooling, valve EVA_2 must open to bypass at least some of the refrigerant to condenser C. The refrigerant that reaches the evaporator thus has less cooling capacity. Valves EVA_1 and EVA_2 are also connected together in complementary mode, controlled by the 4 to 20 mA signal on input S1, from an external regulator.

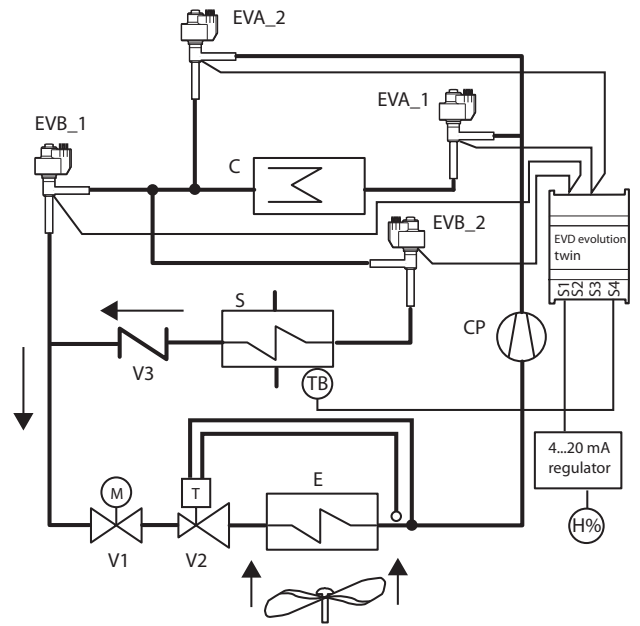

Fig. 5.j

Key:

CP	Compressor	EVA_1,2	Electronic valves connected in complementary mode
C	Condenser	H%	Relative humidity probe
V1	Solenoid valve	TB	Temperature probe
V3	Non-return valve	E	Evaporator
S	Heat exchanger (reheating)	V2	Thermostatic expansion valve

For the wiring, see paragraph 2.11 "General connection diagram".

Transcritical CO₂ gas cooler

This solution for the use of CO₂ in refrigerating systems with a transcritical cycle involves using a gas cooler, that is a refrigerant/air heat exchanger resistant to high pressures, in place of the condenser.

In transcritical operating conditions, for a certain gas cooler outlet temperature, there is pressure that optimises the efficiency of the system:

$$Set = A \cdot T + B$$

Set= pressure set point in a gas cooler with transcritical CO₂

T= gas cooler outlet temperature

Default value: A=3.3, B= -22.7.

In the simplified diagram shown below control is performed by driver A and the simplest solution in conceptual terms is shown. The complications in the systems arise due to the high pressure and the need to optimise efficiency. Driver B is used for superheat control.

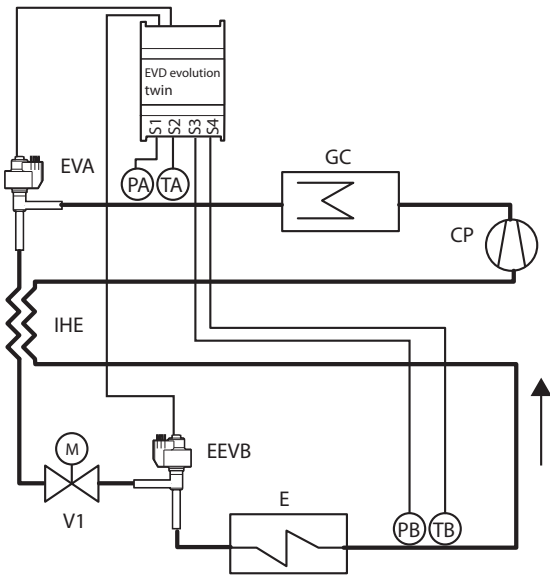

Fig. 5.k

Key:

CP	Compressor	EVA	Electronic valve A
GC	Gas cooler	EEVB	Electronic expansion valve B
E	Evaporator	IHE	Inside heat exchanger
V1	Solenoid valve		

For the wiring, see paragraph 2.11 "General connection diagram".

This involves PID control without any protectors (LowSH, LOP, MOP, see the chapter on Protectors), without any valve unblock procedure. Control is performed on the gas cooler pressure probe value read by input S1, with a set point depending on the gas cooler temperature read by input S2; consequently there is not a set point parameter, but rather a formula: "CO₂ gas cooler pressure set point" = Coefficient A * Tgas cooler (S2) + Coefficient B. The set point calculated will be a variable that is visible in display mode. Control is direct, as the pressure increases, the valve opens.

Parameter/Description	Def.	Min.	Max.	UOM
SPECIAL				
Transcritical CO ₂ : coefficient A	3.3	-100	800	-
Transcritical CO ₂ : coefficient B	-22.7	-100	800	-
CONTROL				
PID: proportional gain	15	0	800	
PID: integral time	150	0	1000	s
PID: derivative time	5	0	800	s

Tab. 5.p

Analogue positioner (4 to 20 mA)

This control function is available for driver A and driver B. Valve A will be positioned linearly depending on the value of the "4 to 20 mA input for analogue valve positioning" read by input S1.

Valve B will be positioned linearly depending on the value of the "4 to 20 mA input for analogue valve positioning" read by input S3.

There is no PID control nor any protection (LowSH, LOP, MOP, see the chapter on Protectors), and no valve unblock procedure.

Forced closing will only occur when digital input DI1 opens for driver A or DI2 for driver B, thus switching between control status and standby. The pre-positioning and repositioning procedures are not performed. Manual positioning can be enabled when control is active or in standby.

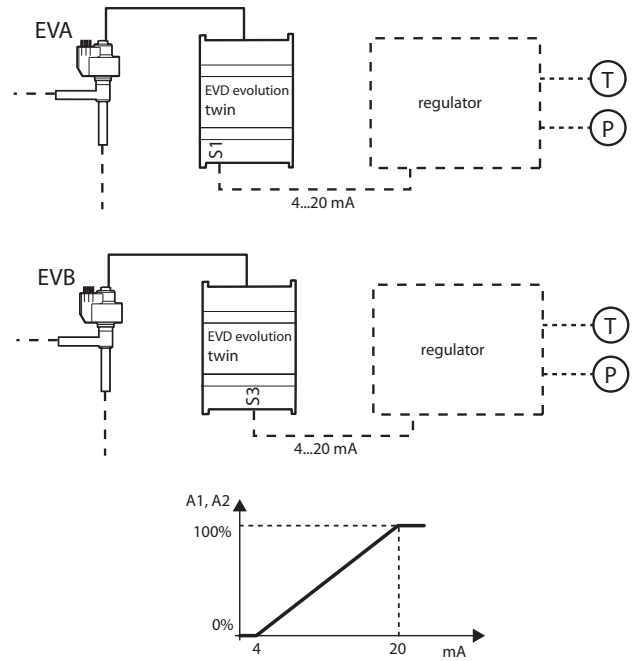

Fig. 5.l

Key:

EVA	Electronic valve A	A1	Valve opening A
EVB	Electronic valve B	A2	Valve opening B

For the wiring, see paragraph 2.11 "General connection diagram".

Analogue positioner (0 to 10 Vdc)

This control function is only available for driver A. The valve will be positioned linearly depending on the value of the "0 to 10 V input for analogue valve positioning" read by input S2.

There is no PID control nor any protection (LowSH, LOP, MOP), and no valve unblock procedure. The opening of digital input DI1 stops control on driver A, with corresponding forced closing of the valve and changeover to standby status.

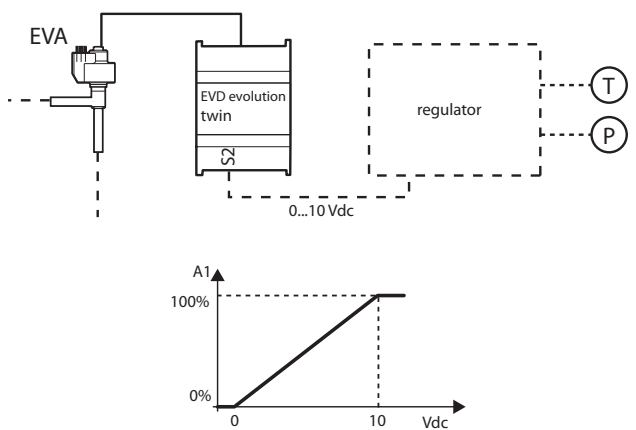

Fig. 5.m

Key:

EVA	Electronic valve A	A1	Valve opening A
-----	--------------------	----	-----------------

For the wiring, see paragraph 2.11 "General connection diagram".

I/O expander for pCO

The EVD Evolution twin driver is connected to the pCO programmable controller via LAN, transferring the probe readings quickly and without filtering. Each driver operates as a simple actuator, and receives the information needed to manage the valves from the pCO.

Parameter/Description	Def.
CONFIGURATION	
Main control	multiplexed showcase/cold room
...	
I/O expander for pCO	

Tab. 5.q

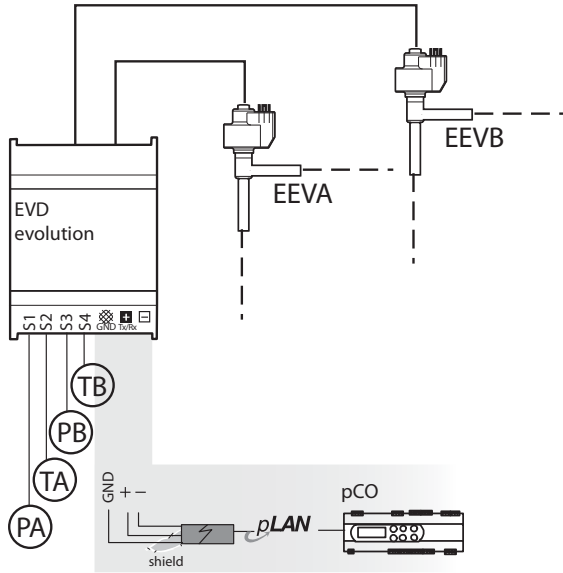

Fig. 5.n

Key:

T	Temperature probe	P	Pressure probe
EEV	Electronic valve		

6. FUNCTIONS

6.1 Power supply mode

EVD evolution twin can be powered at 24 Vac or 24 Vdc. In the event of direct current power supply, after completing the commissioning procedure, to start control set "Power supply mode" parameter=1.

Parameter/Description	Def.	Min.	Max.	UOM
SPECIAL				
Power supply mode	0	0	1	-
0=24 Vac				
1= 24 Vdc				

Tab. 6.a

Important: with direct current power supply, in the event of power failures emergency closing of the valve is not performed, even if the EVBAT00400 battery module is connected.

6.2 Network connection

To connect an RS485/Modbus® controller to the network, as well as the network address parameter (see paragraph 4.2), the communication speed also needs to be set, in bit/s, using the "network settings" parameter.

Parameter/Description	Def.	Min.	Max.	UOM
SPECIAL				
Network settings	2	0	2	bit/s
0 = 4800; 1 = 9600; 2 = 19200				

Tab. 6.b

Note: the following Modbus® serial communication parameters cannot be set:

- byte size: 8 bits;
- stop bits: 2;
- parity: none;
- transmission mode: RTU.

6.3 Inputs and outputs

Analogue inputs

The parameters in question concern the choice of the type of pressure probe S1 and S3 and the choice of the temperature probe S2 and S4, as well as the possibility to calibrate the pressure and temperature signals. As regards the choice of pressure probes S1 and S3, see the chapter on "Commissioning".

Inputs S2, S4

The options are standard NTC probes, high temperature NTC, combined temperature and pressure probes and 0 to 10 Vdc input. For S4 the 0 to 10 Vdc input is not available. When choosing the type of probe, the minimum and maximum alarm values are automatically set. See the chapter on "Alarms".

Type	CAREL code	Range
CAREL NTC (10KΩ at 25°C)	NTCO**HP00	-50T105°C
	NTCO**WF00	
	NTCO**HF00	
CAREL NTC-HT HT (50KΩ at 25°C)	NTCO**HT00	0T120°C (150 °C for 3000 h)
Combined NTC	SPKP**T0	-40T120°C

Important: for combined NTC probes, also select the parameter relating to the corresponding ratiometric pressure probe.

Parameter/description	Def.
CONFIGURATION	
Probe S2:	CAREL NTC
1= CAREL NTC; 2= CAREL NTC-HT high T.; 3= Combined NTC SPKP**T0; 4= 0 to 10 V external signal	
Probe S4:	CAREL NTC
1= CAREL NTC; 2= CAREL NTC-HT high T.; 3= Combined NTC SPKP**T0	

Tab. 6.c

Calibrating pressure probes S1, S3 and temperature probes S2 and S4 (offset and gain parameters)

If needing to be calibrate:

- the pressure probe, S1 and/or S3, the offset parameter can be used, which represents a constant that is added to the signal across the entire range of measurement, and can be expressed in barg/psig. If the 4 to 20 mA signal coming from an external controller on input S1 and/or S3 needs to be calibrated, both the offset and the gain parameters can be used, the latter which modifies the gradient of the line in the field from 4 to 20 mA.
- the temperature probe, S2 and/or S4, the offset parameter can be used, which represents a constant that is added to the signal across the entire range of measurement, and can be expressed in °C/°F. If the 0 to 10 Vdc signal coming from an external controller on input S2 needs to be calibrated, both the offset and the gain parameters can be used, the latter which modifies the gradient of the line in the field from 0 to 10 Vdc.

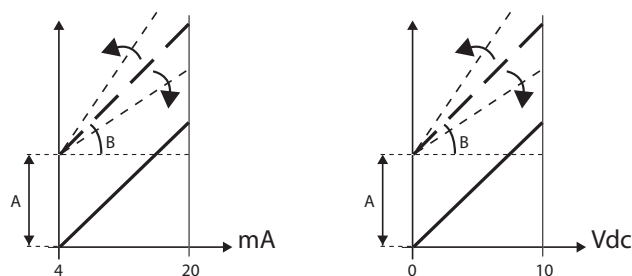

Fig. 6.a

Key:
A= offset,
B= gain

Parameter/description	Def.	Min.	Max.	UOM
Probes				
S1: calibration offset	0	-60 (-870), -60	60 (870), 60	barg (psig), mA
S1: calibration gain, 4 to 20 mA	1	-20	20	-
S2: calibration offset	0	-20 (-36)	20 (36)	°C (°F), volt
S2: calibration gain, 0 to 10 V	1	-20	20	-
S3: calibration offset	0	-60 (-870)	60 (870)	barg (psig)
S3: calibration gain, 4 to 20 mA	1	-20	20	-
S4: calibration offset	0	-20 (-36)	20 (36)	°C (°F)

Tab. 6.d

Digital inputs

The functions of digital inputs 1 and 2 can be set by parameter, as shown in the table below:

Parameter/description	Def.	Min.	Max.	UOM
CONFIGURATION				
D11 configuration	5/6	1	7	-
1= Disabled				
2= Valve regulation optimization after defrost				
3= Discharged battery alarm management				
4= Valve forced open (at 100%)				
5= Regulation start/stop				
6= Regulation backup				
7= Regulation security				
CONTROL				
Start delay after defrost	10	0	60	min

Tab. 6.e

Valve regulation optimization after defrost: the selected digital input tells the driver the current defrost status.

Defrost active = contact closed.

Access Manufacturer programming mode to set the start delay after defrost; this parameter is common to both drivers.

Discharged battery alarm management: this setting can only be selected if the controller power supply is 24 Vac. If the selected digital input is connected to the battery charge module for EVD evolution, EVBAT00400, the controller signals discharged or faulty batteries, so as to generate an alarm message and warn the service technicians that maintenance is required.

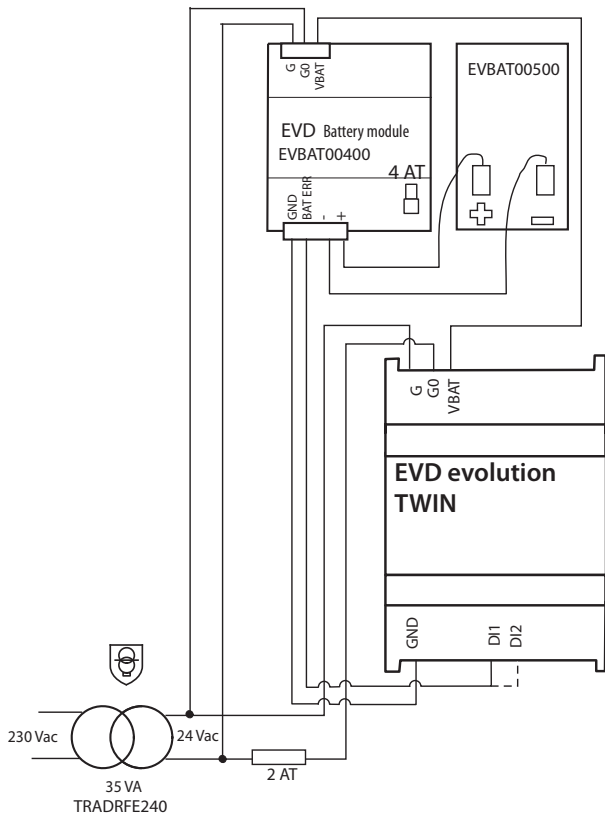

Fig. 6.b

Valve forced open: when the digital input closes, the valve opens completely (100%), unconditionally. When the contact opens again the valve closes and moves to the position defined by the parameter “valve opening at start-up” for the pre-position time. Control can then start.

Regulation start/stop:

digital input closed: control active;
digital input open: driver in standby (see the paragraph “Control status”);

Important: this setting excludes activation/deactivation of control via the network. See the following functions.

- Regulation backup: if there is a network connection and communication fails, the driver checks the status of the digital input to determine whether control is active or in standby;
- Regulation security: if there is a network connection, before control is activated the driver must receive the control activation signal and the selected digital input must be closed. If the digital input is open, the driver always remains in standby.

Priority of digital inputs

In certain cases the setting of digital inputs 1 and 2 may be incompatible (e.g. no regulation start/stop). The problem thus arises to determine which function each driver needs to perform.

Consequently, each type of function is assigned a priority, primary (PRIM) or secondary (SEC), as shown in the table:

DI1/DI2 configuration	Type of function
1=Disabled	SEC
2=Valve regulation optimization after defrost	SEC
3=Discharged battery alarm management	SEC
4=Valve forced open (at 100%)	SEC
5=Regulation start/stop	PRIM
6=Regulation backup	PRIM
7=Regulation security	PRIM

There are four possible cases of digital input configurations with primary or secondary functions.

Case	Function set		Driver A		Driver B	
	DI1	DI2	Function performed by digital input		Function performed by digital input	
			PRIM	SEC	PRIM	SEC
1	PRIM	PRIM	DI1	-	DI2	-
2	PRIM	SEC	DI1	DI2	DI1	-
3	SEC	PRIM	DI2	-	DI2	DI1
4	SEC	SEC	Regulation backup driver A (supervisor variable)		Regulation backup driver B (supervisor variable)	

Note that:

- if digital inputs 1 and 2 are set to perform a PRIM function, driver A performs the function set by digital input 1 and driver B the function set by digital input 2;
- if digital inputs 1 and 2 are set to perform a PRIM and SEC function respectively, driver A and driver B perform the PRIM function set on digital input DI1. Driver A will also perform the SEC function set on digital input DI2;
- if digital inputs 1 and 2 are set to perform a SEC and PRIM function respectively, driver A and driver B perform the PRIM function set on digital input DI2. Driver B will also perform the SEC function set on digital input DI1;
- if digital inputs 1 and 2 are set to perform a SEC function, driver A will perform the SEC function set on input DI1 and driver B will perform the SEC function set on input DI2. Each driver will be set to “Regulation backup”, with the value of the digital input determined respectively by the supervisor variables:
 - Regulation backup from supervisor (driver A);
 - Regulation backup from supervisor (driver B).

Examples

Example 1: assuming an EVD Evolution twin controller connected to the LAN. In this case, the start/stop control will come from the network.

The two digital inputs can be configured for:

1. valve regulation optimization after defrost (SEC function);
2. regulation backup (PRIM function).

With reference to the previous table:

- in case 2, when there is no communication both driver A and driver B will be enabled for control by digital input 1, and digital input 2 will determine when control stops to run the defrost for driver A only;
- in case 3 when there is no communication digital input 2 will activate control for both driver A and driver B. Digital input 1 will determine when control stops to run the defrost for driver B only.

Example 2: assuming an EVD Evolution twin controller in stand-alone operation. In this case, the start/stop control will come from the digital input.

The following cases are possible:

1. start / stop driver A/B from inputs DI1/DI2 (case 1);
2. simultaneous start / stop of both drivers A/B from input DI1 (case 2); input DI2 can be used for discharged battery alarm management.

Relay outputs

The relay outputs can be configured as:

- alarm relay output. See the chapter on Alarms;
- solenoid valve control;
- electronic expansion valve status signal relay. The relay contact is only open if the valve is closed (opening=0%). As soon as control starts (opening >0%, with hysteresis), the relay contact is closed

Parameter/description	Def.
CONFIGURATION	
Relay configuration:	Alarm relay
1= Disabled; 2= Alarm relay (open when alarm active);	
3= Solenoid valve relay (open in standby); 4= Valve + alarm relay (open in standby and control alarms)	
5= Reversed alarm relay (closed in case of alarm); 6= Valve status relay (open if valve is closed)	

Tab. 6.f

6.4 Control status

The electronic valve controller has 8 different types of control status, each of which may correspond to a specific phase in the operation of the refrigeration unit and a certain status of the controller-valve system.

The status may be as follows:

- **forced closing:** initialisation of the valve position when switching the instrument on;
- **standby:** no temperature control, unit OFF;
- **wait:** opening of the valve before starting control, also called pre-positioning, when powering the unit and in the delay after defrosting;
- **control:** effective control of the electronic valve, unit ON;
- **positioning:** step-change in the valve position, corresponding to the start of control when the cooling capacity of the controlled unit varies (only for pLAN EVD connected to a pCO);
- **stop:** end of control with the closing of the valve, corresponds to the end of temperature control of the refrigeration unit, unit OFF;
- **valve motor error recognition:** see paragraph 9.5;
- **tuning in progress:** see paragraph 5.3

Forced closing

Forced closing is performed after the controller is powered-up and corresponds to a number of closing steps equal to the parameter "Closing steps", based on the type valve selected. This is used to realign the valve to the physical position corresponding to completely closed. The driver and the valve are then ready for control and both aligned at 0 (zero). On power-up, first a forced closing is performed, and then the standby phase starts.

Parameter/description	Def.	Min.	Max.	UOM
VALVE				
EEV closing steps	500	0	9999	step

Tab. 6.g

The valve is closed in the event of power failures with 24 Vac power supply when the EVBAT00400 battery module is connected. In this case, the parameter "Forced valve closing not completed", visible only on the supervisor, is forced to 1. If when restarting forced closing of the valve was not successful:

1. the Master programmable controller checks the value of the parameter and if this is equal to 1, decides the best strategy to implement based on the application;
2. EVD Evolution twin does not make any decision and positions the valve as explained in the paragraph "Pre-positioning/start control". The parameter is reset to 0 (zero) by the Master controller (e.g. pCO). EVD Evolution twin resets the parameter to 0 (zero) only if forced emergency closing is completed successfully

Standby

Standby corresponds to a situation of rest in which no signals are received to control the electronic valve. This normally occurs when:

- the refrigeration unit stops operating, either when switched off manually (e.g. from the button, supervisor) or when reaching the control set point;
- during defrosts, except for those performed by reversing of the cycle (or hot gas bypass).

In general, it can be said that electronic valve control is in standby when the compressor stops or the control solenoid valve closes. The valve is closed or open, delivering around 25% of the flow-rate of refrigerant, based on the setting of the "valve open in standby" parameter.

In this phase, manual positioning can be activated.

Parameter/description	Def.	Min.	Max.	UOM
CONTROL				
Valve open in standby 0=disabled=valve closed; 1=enabled = valve open 25%	0	0	1	-

Tab. 6.h

Prepositioning/start control

If during standby a control request is received, before starting control the valve is moved to a precise initial position.

The pre-position time is the time the valve is held in a steady position based on the parameter "Valve opening at start-up".

Parameter/description	Def.	Min.	Max.	UOM
CONTROL				
Pre-position time	6	0	18000	s
Valve opening at start-up (evaporator/valve capacity ratio)	50	0	100	%

Tab. 6.i

The valve opening parameter should be set based on the ratio between the rated cooling capacity of the evaporator and the valve (e.g. rated evaporator cooling capacity: 3kW, rated valve cooling capacity: 10kW, valve opening = 3/10 = 33%).

If the capacity request is 100%:

Opening (%)= (Valve opening at start-up);

If the capacity request is less than 100% (capacity control):

Opening (%)= (Valve opening at start-up) x (Current unit cooling capacity), where the current unit cooling capacity is sent to the driver via pLAN by the pCO controller. If the driver is stand-alone, this is always equal to 100%.

Note:

- this procedure is used to anticipate the movement and bring the valve significantly closer to the operating position in the phases immediately after the unit starts;
- if there are problems with liquid return after the refrigeration unit starts or in units that frequently switch on-off, the valve opening at start-up must be decreased. If there are problems with low pressure after the refrigeration unit starts, the valve opening must be increased.

Wait

When the calculated position has been reached, regardless of the time taken (this varies according to the type of valve and the objective position), there is a constant 5 second delay before the actual control phase starts. This is to create a reasonable interval between standby, in which the variables have no meaning, as there is no flow of refrigerant, and the effective control phase.

Control

The control request for each driver can be received, respectively, by the closing of digital input 1 or 2, via the network (pLAN). The solenoid or the compressor are activated when the valve, following the pre-positioning procedure, has reached the calculated position. The following figure represents the sequence of events for starting control of the refrigeration unit.

Control delay after defrost

Some types of refrigerating cabinets have problems controlling the electronic valve in the operating phase after a defrost. In this period (10 to 20 min after defrosting), the superheat measurement may be altered by the high temperature of the copper pipes and the air, causing excessive opening of the electronic valve for extended periods, in which there is return of liquid to the compressors that is not detected by the probes connected to the driver. In addition, the accumulation of refrigerant in the evaporator in this phase is difficult to dissipate in a short time, even after the probes have started to correctly measure the presence of liquid (superheat value low or null).

The driver can receive information on the defrost phase in progress, via the digital input. The "Start delay after defrost" parameter is used to set a delay when control resumes so as to overcome this problem. During this delay, the valve will remain in the pre-positioning point, while all the normal probe alarm procedures, etc. are managed.

Parameter/description	Def.	Min.	Max.	UOM
CONTROL				
Start delay after defrost	10	0	60	min

Tab. 6.j



Important: if the superheat temperature should fall below the set point, control resumes even if the delay has not yet elapsed.

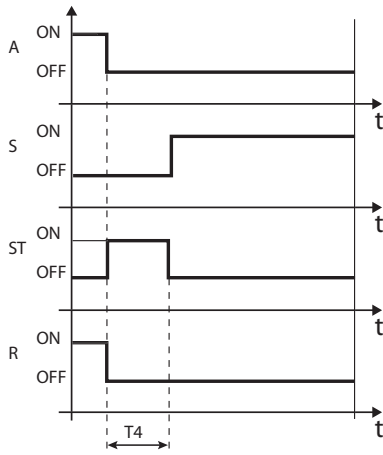

Fig. 6.c

Key:

A	Control request	W	Wait
S	Standby	T1	Pre-position time
P	Pre-positioning	T2	Start delay after defrost
R	Control	t	Time

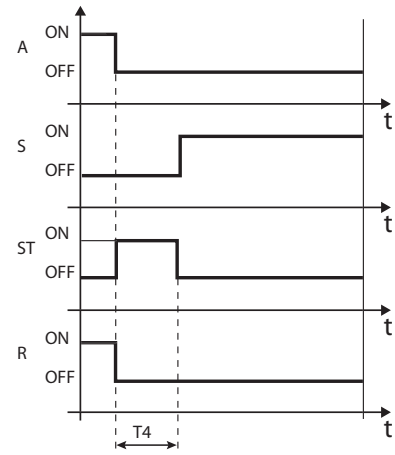

Fig. 6.e

Key:

A	Control request	R	Control
S	Standby	T4	Stop position time
ST	Stop	t	Time

Positioning (change cooling capacity)

This control status is only valid for the pLAN controller. If there is a change in unit cooling capacity of at least 10%, sent from the pCO via the pLAN, the valve is positioned proportionally. In practice, this involves repositioning starting from the current position in proportion to how much the cooling capacity of the unit has increased or decreased in percentage terms. When the calculated position has been reached, regardless of the time taken (this varies according to the type of valve and the position), there is a constant 5 second delay before the actual control phase starts.

Note: if information is not available on the variation in unit cooling capacity, this will always be considered as operating at 100% and therefore the procedure will never be used. In this case, the PID control must be more reactive (see the chapter on Control) so as to react promptly to variations in load that are not communicated to the driver.

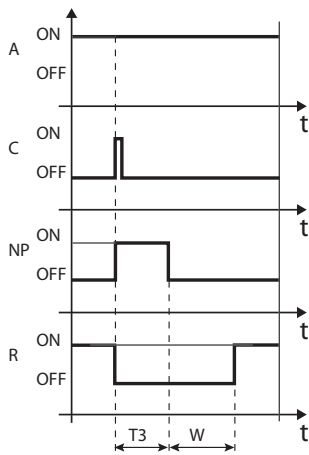

Fig. 6.d

Key:

A	Control request	T3	Repositioning time
C	Change capacity	W	Wait
NP	Repositioning	t	Time
R	Control		

Stop/end control

The stop procedure involves closing the valve from the current position until reaching 0 steps, plus a further number of steps so as to guarantee complete closing. Following the stop phase, the valve returns to standby.

6.5 Special control status

As well as normal control status, the driver can have 3 special types of status related to specific functions:

- **manual positioning:** this is used to interrupt control so as to move the valve, setting the desired position;
- **recover physical valve position:** recover physical valve steps when fully opened or closed;
- **unblock valve:** forced valve movement if the driver considers it to be blocked.

Manual positioning

Manual positioning can be activated at any time during the standby or control phase. Manual positioning, once enabled, is used to freely set the position of the valve using the corresponding parameter.

Parameter/Description	Def.	Min.	Max.	UOM
CONTROL				
Enable manual valve positioning	0	0	1	-
Manual valve position	0	0	9999	step

Tab. 6.k

Control is placed on hold, all the system and control alarms are enabled, however neither control nor the protectors can be activated. Manual positioning thus has priority over any status/protection of the driver.

- Note:**
- the manual positioning status is NOT saved when restarting after a power failure;
 - in for any reason the valve needs to be kept stationary after a power failure, proceed as follows:
 - remove the valve stator;
 - in Manufacturer programming mode, under the configuration parameters, set the PID proportional gain =0. The valve will remain stopped at the initial opening position, set by corresponding parameter.

Recover physical valve position

Parameter/Description	Def.	Min.	Max.	UOM
VALVE				
Synchronise valve position in opening	1	0	1	-
Synchronise valve position in closing	1	0	1	-

Tab. 6.l

This procedure is necessary as the stepper motor intrinsically tends to lose steps during movement. Given that the control phase may last continuously for several hours, it is probable that from a certain time on the estimated position sent by the valve controller does not correspond exactly to the physical position of the movable element. This means that when the driver reaches the estimated fully closed or fully open position, the valve may physically not be in that position. The "Synchronisation" procedure allows the driver to perform a certain number of steps in the suitable direction to realign the valve when fully opened or closed.

 **Note:**

- realignment is in intrinsic part of the forced closing procedure and is activated whenever the driver is stopped/started and in the standby phase;
- the possibility to enable or disable the synchronisation procedure depends on the mechanics of the valve. When the setting the “valve” parameter, the two synchronisation parameters are automatically defined. The default values should not be changed.

Unblock valve

This procedure is only valid when the driver is performing superheat control. Unblock valve is an automatic safety procedure that attempts to unblock a valve that is supposedly blocked based on the control variables (superheat, valve position). The unblock procedure may or may not succeed depending on the extent of the mechanical problem with the valve. If for 10 minutes the conditions are such as to assume the valve is blocked, the procedure is run a maximum of 5 times. The symptoms of a blocked valve do not necessarily mean a mechanical blockage. They may also represent other situations:

- mechanical blockage of the solenoid valve upstream of the electronic valve (if installed);
- electrical damage to the solenoid valve upstream of the electronic valve;
- blockage of the filter upstream of the electronic valve (if installed);
- electrical problems with the electronic valve motor;
- electrical problems in the driver-valve connection cables;
- incorrect driver-valve electrical connection;
- electronic problems with the valve control driver;
- secondary fluid evaporator fan/pump malfunction;
- insufficient refrigerant in the refrigerant circuit;
- refrigerant leaks;
- lack of subcooling in the condenser;
- electrical/mechanical problems with the compressor;
- processing residues or moisture in the refrigerant circuit.



Note: the valve unblock procedure is nonetheless performed in each of these cases, given that it does not cause mechanical or control problems. Therefore, also check these possible causes before replacing the valve.

7. PROTECTORS

These are additional functions that are activated in specific situations that are potentially dangerous for the unit being controlled. They feature an integral action, that is, the action increases gradually when moving away from the activation threshold. They may add to or overlap (disabling) normal PID superheat control. By separating the management of these functions from PID control, the parameters can be set separately, allowing, for example, normal control that is less reactive yet much faster in responding when exceeding the activation limits of one of the protectors.

7.1 Protectors

There are 3 protectors:

- LowSH, low superheat;
- LOP, low evaporation temperature;
- MOP, high evaporation temperature;

The protectors have the following main features:

- activation threshold: depending on the operating conditions of the controlled unit, this is set in Service programming mode;
- integral time, which determines the intensity (if set to 0, the protector is disabled): set automatically based on the type of main control;
- alarm, with activation threshold (the same as the protector) and delay (if set to 0 disables the alarm signal).

Note: the alarm signal is independent from the effectiveness of the protector, and only signals that the corresponding threshold has been exceeded. If a protector is disabled (null integration time), the relative alarm signal is also disabled.

Each protector is affected by the proportional gain parameter (K) for the PID superheat control. The higher the value of K, the more intense the reaction of the protector will be.

Characteristics of the protectors

Protection	Reaction	Reset
LowSH	Intense closing	Immediate
LOP	Intense opening	Immediate
MOP	Moderate closing	Controlled

Tab. 7.a

Reaction: summary description of the type of action in controlling the valve.

Reset: summary description of the type of reset following the activation of the protector. Reset is controlled to avoid swings around the activation threshold or immediate reactivation of the protector.

LowSH (low superheat)

The protector is activated so as to prevent the return of liquid to the compressor due to excessively low superheat values.

Parameter/description	Def.	Min.	Max.	UOM
CONTROL				
LowSH protection: threshold	5	-40 (-72)	SH set point	K (°F)
LowSH protection: integral time	15	0	800	s
ALARM CONFIGURATION				
Low superheat alarm delay (LowSH) (0= alarm disabled)	300	0	18000	s

Tab. 7.b

When the superheat value falls below the threshold, the system enters low superheat status, and the intensity with which the valve is closed is increased: the more the superheat falls below the threshold, the more intensely the valve will close. The LowSH threshold, must be less than or equal to the superheat set point. The low superheat integration time indicates the intensity of the action: the lower the value, the more intense the action.

The integral time is set automatically based on the type of main control.

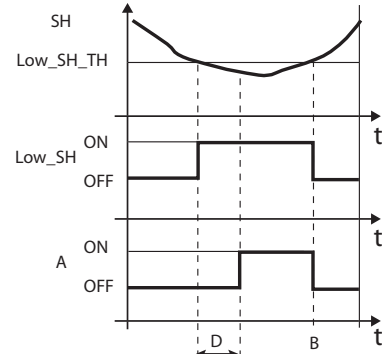

Fig. 7.a

Key:

SH	Superheat	A	Alarm
Low_SH_TH	Low_SH protection threshold	D	Alarm delay
Low_SH	Low_SH protection	t	Time
B	Automatic alarm reset		

LOP (low evaporation pressure)

LOP= Low Operating Pressure

The LOP protection threshold is applied as a saturated evaporation temperature value so that it can be easily compared against the technical specifications supplied by the manufacturers of the compressors. The protector is activated so as to prevent too low evaporation temperatures from stopping the compressor due to the activation of the low pressure switch. The protector is very useful in units with compressors on board (especially multi-stage), where when starting or increasing capacity the evaporation temperature tends to drop suddenly.

When the evaporation temperature falls below the low evaporation temperature threshold, the system enters LOP status and the intensity with which the valve is opened is increased. The further the temperature falls below the threshold, the more intensely the valve will open. The integral time indicates the intensity of the action: the lower the value, the more intense the action.

Parameter/description	Def.	Min.	Max.	UOM
CONTROL				
LOP protection: threshold	-50	-60 (-76)	MOP protection: threshold	°C (°F)
LOP protection: integral time	0	0	800	s
ALARM CONFIGURATION				
Low evaporation temperature alarm delay (LOP) (0= alarm disabled)	300	0	18000	s

Tab. 7.c

The integral time is set automatically based on the type of main control.



Note:

- the LOP threshold must be lower than the rated evaporation temperature of the unit, otherwise it would be activated unnecessarily, and greater than the calibration of the low pressure switch, otherwise it would be useless. As an initial approximation it can be set to a value exactly half-way between the two limits indicated;
- the protector has no purpose in multiplexed systems (showcases) where the evaporation is kept constant and the status of the individual electronic valve does not affect the pressure value;
- the LOP alarm can be used as an alarm to highlight refrigerant leaks by the circuit. A refrigerant leak in fact causes an abnormal lowering of the evaporation temperature that is proportional, in terms of speed and extent, to the amount of refrigerant dispersed.

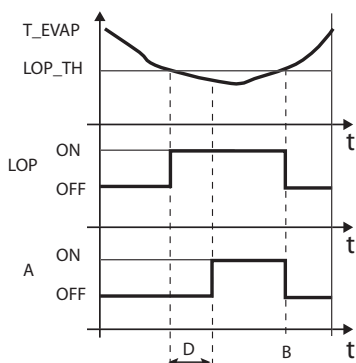

Fig. 7.b

Key:

T_EVAP	Evaporation temperature	D	Alarm delay
LOP_TH	Low evaporation temperature protection threshold	ALARM	Alarm
LOP	LOP protection	t	Time
B	Automatic alarm reset		

MOP (high evaporation pressure)

MOP= Maximum Operating Pressure.

The MOP protection threshold is applied as a saturated evaporation temperature value so that it can be easily compared against the technical specifications supplied by the manufacturers of the compressors. The protector is activated so as to prevent too high evaporation temperatures from causing an excessive workload for the compressor, with consequent overheating of the motor and possible activation of the thermal protector. The protector is very useful in units with compressor on board if starting with a high refrigerant charge or when there are sudden variations in the load. The protector is also useful in multiplexed systems (showcases), as allows all the utilities to be enabled at the same time without causing problems of high pressure for the compressors. To reduce the evaporation temperature, the output of the refrigeration unit needs to be decreased. This can be done by controlled closing of the electronic valve, implying superheat is no longer controlled, and an increase in the superheat temperature. The protector will thus have a moderate reaction that tends to limit the increase in the evaporation temperature, keeping it below the activation threshold while trying to stop the superheat from increasing as much as possible. Normal operating conditions will not resume based on the activation of the protector, but rather on the reduction in the refrigerant charge that caused the increase in temperature. The system will therefore remain in the best operating conditions (a little below the threshold) until the load conditions change.

Parameter/description	Def.	Min.	Max.	UOM
CONTROL				
MOP protection: threshold	50	LOP protection: threshold	200 (392)	°C (°F)
MOP protection: integral time	20	0	800	s
ALARM CONFIGURATION				
High evaporation temperature alarm delay (MOP) (0= alarm disabled)	600	0	18000	s

Tab. 7.d

The integral time is set automatically based on the type of main control.

When the evaporation temperature rises above the MOP threshold, the system enters MOP status, superheat control is interrupted to allow the pressure to be controlled, and the valve closes slowly, trying to limit the evaporation temperature. As the action is integral, it depends directly on the difference between the evaporation temperature and the activation threshold. The more the evaporation temperature increases with reference to the MOP threshold, the more intensely the valve will close. The integral time indicates the intensity of the action: the lower the value, the more intense the action.

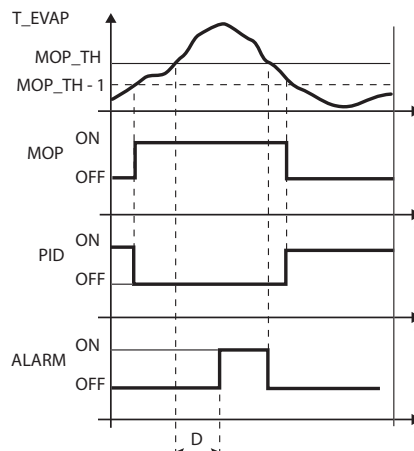

Fig. 7.c

Key:

T_EVAP	Evaporation temperature	MOP_TH	MOP threshold
PID	PID superheat control	ALARM	Alarm
MOP	MOP protection	t	Time
D	Alarm delay		



Important: the MOP threshold must be greater than the rated evaporation temperature of the unit, otherwise it would be activated unnecessarily. The MOP threshold is often supplied by the manufacturer of the compressor. It is usually between 10°C and 15 °C.

If the closing of the valve also causes an excessive increase in the suction temperature (S2) above the set threshold – only set via supervisor (PlantVisor, pCO, VPM), not on the display - the valve will be stopped to prevent overheating the compressor windings, awaiting a reduction in the refrigerant charge. If the MOP protection function is disabled by setting the integral time to zero, the maximum suction temperature control is also deactivated.

Parameter/description	Def.	Min.	Max.	UOM
CONTROL				
MOP protection: suction temperature threshold	30	-60 (-72)	200 (392)	°C(°F)

Tab. 7.e

At the end of the MOP protection function, superheat control restarts in a controlled manner to prevent the evaporation temperature from exceeding the threshold again..

8. TABLE OF PARAMETERS

8.1 Table of parameters, driver A

user *	Parameter/description	Def.	Min.	Max.	UOM	Type **	CAREL SVP	Modbus®	Note
CONFIGURATION									
A	Network address	pLAN: 30 others: 198	1	207	-	I	11	138	CO
A	Refrigerant: 1= R22 2= R134a 3= R404A 4= R407C 5= R410A 6= R507A 7= R290 8= R600 9= R600a 10= R717 11= R744 12= R728 13= R1270 14= R417A 15= R422D 16= R413A 17= R422A 18= R423A 19= R407A 20= R427A	R404A	-	-	-	I	13	140	-
A	Valve: 1= CAREL E [®] V 2= Alco EX4 3= Alco EX5 4= Alco EX6 5= Alco EX7 6= Alco EX8 330 Hz recommended CAREL 7= Alco EX8 500 Hz specific Alco 8= Sporlan SEI 0.5-11 9= Sporlan SER 1.5-20 10= Sporlan SEI 30 11= Sporlan SEI 50 12= Sporlan SEH 100 13= Sporlan SEH 175 14= Danfoss ETS 12.5-25B 15= Danfoss ETS 50B 16= Danfoss ETS 100B 17= Danfoss ETS 250 18= Danfoss ETS 400 19= two CAREL E [®] V connected together 20= Sporlan SER(I)G, J, K 21= Danfoss CCM 10-20-30 22= Danfoss CCM 40	CAREL E [®] V	-	-	-	I	14	141	
A	Probe S1: Ratiometric (OUT=0 to 5 V) Electronic (OUT=4 - 20 mA) 1= -1 to 4.2 barg 8= -0.5 to 7 barg 2= 0.4 to 9.3 barg 9= 0 to 10 barg 3= -1 to 9.3 barg 10= 0 to 18.2 barg 4= 0 to 17.3 barg 11= 0 to 25 barg 5= 0.85 to 34.2 barg 12= 0 to 30 barg 6= 0 to 34.5 barg 13= 0 to 44.8 barg 7= 0 to 45 barg 14= remote, -0.5 to 7 barg 15= remote, 0 to 10 barg 16= remote, 0 to 18.2 barg 17= remote, 0 to 25 barg 18= remote, 0 to 30 barg 19= remote, 0 to 44.8 barg 20= 4 to 20mA external signal 21= -1 to 12.8 barg 22= 0 to 20.7 barg 23= 1.86 to 43.0 barg	Ratiometric: -1 to 9.3 barg	-	-	-	I	16	143	CO

user *	Parameter/description	Def.	Min.	Max.	UOM	Type **	CAREL SVP	Modbus®	Note
A	Main control: 1= Multiplexed showcase/cold room 2= Showcase/cold room with compressor on board 3= "Perturbed" showcase/cold room 4= Showcase/cold room with sub-critical CO ₂ 5= R404A condenser for sub-critical CO ₂ 6= Air-conditioner/chiller with plate heat exchanger 7= Air-conditioner/chiller with tube bundle heat exchanger 8= Air-conditioner/chiller with finned coil heat exchanger 9= Air-conditioner/chiller with variable cooling capacity 10= "Perturbed" air-conditioner/chiller 11= EPR back pressure 12= Hot gas bypass by pressure 13= Hot gas bypass by temperature 14= Transcritical CO ₂ gas cooler 15= Analogue positioner (4 to 20 mA) 16= Analogue positioner (0 to 10 V) 17= Air-conditioner/chiller or showcase/cold room with adaptive control 18= Air-conditioner/chiller with Digital Scroll compressor 19= AC or chiller with SIAM ANB scroll compressor (CANNOT BE SELECTED) 20= superheat regulation with 2 temperature probes (CANNOT BE SELECTED) 21= I/O expander for pCO (*) (*)= parameter common to driver A and driver B	Multiplexed showcase/cold room	-	-	-	I	15	142	-
A	Probe S2: 1= CAREL NTC 2= CAREL NTC-HT hi temp. 3= Combined NTC SPKP**TO 4= 0 to 10 V external signal	CAREL NTC	-	-	-	I	17	144	CO
A	Auxiliary control: Disabled (NOT MODIFIABLE)	-	-	-	-	I	18	145	CO
A	Probe S3: Ratiometric (OUT=0 to 5 V) Electronic (OUT=4 - 20 mA) 1= -1 to 4.2 barg 8= -0.5 to 7 barg 2= 0.4 to 9.3 barg 9= 0 to 10 barg 3= -1 to 9.3 barg 10= 0 to 18.2 barg 4= 0 to 17.3 barg 11= 0 to 25 barg 5= 0.85 to 34.2 barg 12= 0 to 30 barg 6= 0 to 34.5 barg 13= 0 to 44.8 barg 7= 0 to 45 barg 14= remote, -0.5 to 7 barg 15= remote, 0 to 10 barg 16= remote, 0 to 18.2 barg 17= remote, 0 to 25 barg 18= remote, 0 to 30 barg 19= remote, 0 to 44.8 barg 20= 4 to 20mA external signal 21= -1 to 12.8 barg 22= 0 to 20.7 barg 23= 1.86 to 43.0 barg)	Ratiometric: -1 to 9.3 barg	-	-	-	I	19	146	CO
A	Relay configuration: 1= Disabled 2= Alarm relay (open when alarm active) 3= Solenoid valve relay (open in standby) 4= Valve + alarm relay (open in standby and control alarms) 5= Reversed alarm relay (closed in case of alarm) 6= Valve status relay (open if valve is closed)	Alarm relay	-	-	-	I	12	139	-
A	Probe S4: 1= CAREL NTC 2= CAREL NTC-HT high temperature 3= Combined NTC SPKP**TO	CAREL NTC	-	-	-	I	20	147	-
A	DI2 Configuration: 1= Disabled 2= Valve regulation optimization after defrost 3= Discharged battery alarm management 4= Valve forced open (at 100%) 5= Regulation start/stop 6= Regulation backup 7= Regulation security	Regulation start/stop (tLAN-RS485) / Regulation backup (pLAN)	-	-	-	I	10	137	CO

user*	Parameter/description	Def.	Min.	Max.	UOM	Type**	CAREL SVP	Modbus®	Note
C	Variable 1 on display: 1= Valve opening 2= Valve position 3= Current cooling capacity 4= Set point control 5= Superheat 6= Suction temperature 7= Evaporation temperature 8= Evaporation pressure 9= Condensing temperature 10= Condensing pressure 11= Modulating thermostat temperature(*) 12= EPR pressure 13= Hot gas bypass pressure 14= Hot gas bypass temperature 15= CO ₂ gas cooler outlet temperature 16= CO ₂ gas cooler outlet pressure 17= CO ₂ gas cooler pressure set point 18= Probe S1 reading 19= Probe S2 reading 20= Probe S3 reading 21= Probe S4 reading 22= 4 to 20 mA input 23= 0 to 10 V input (*) CANNOT BE SELECTED	Superheat	-	-	-	I	45	172	-
C	Variable 2 on display (see variable 1 on display)	Valve opening	-	-	-	I	46	173	-
C	Probe S1 alarm management: 1= No action 2= Forced valve closing 3= Valve in fixed position 4= Use backup probe S3 (*) (*) CANNOT BE SELECTED	Valve in fixed position	-	-	-	I	24	151	CO
C	Probe S2 alarm management: 1= No action 2= Forced valve closing 3= Valve in fixed position 4= Use backup probe S4 (*) (*) CANNOT BE SELECTED	Valve in fixed position	-	-	-	I	25	152	CO
C	Probe S3 alarm management: 1= No action 2= Forced valve closing 3= Valve in fixed position	No action	-	-	-	I	26	153	CO
C	Probe S4 alarm management: 1= No action 2= Forced valve closing 3= Valve in fixed position	No action	-	-	-	I	27	154	CO
C	Unit of measure: 1= °C/K/barg; 2= °F/psig	°C/K/barg	-	-	-	I	21	148	CO
A	DI1 configuration 1= Disabled 2= Valve regulation optimization after defrost 3= Discharged battery alarm management 4= Valve forced open (at 100%) 5= Regulation start/stop 6= Regulation backup 7= Regulation security	Regulation start/stop (tLAN-RS485) / Regulation backup (pLAN)	-	-	-	I	85	212	CO
C	Language: Italiano; English	Italiano	-	-	-				CO
PROBES									
C	S1: calibration offset	0	-60 (-870), -60	60 (870), 60	barg (psig) mA	A	34	33	CO
C	S1: calibration gain, 4 to 20 mA	1	-20	20	-	A	36	35	CO
C	Pressure S1: MINIMUM value	-1	-20 (-290)	Pressure S1: MAXIMUM value	barg (psig)	A	32	31	CO
C	Pressure S1: MAXIMUM value	9.3	Pressure S1: MINIMUM value	200 (2900)	barg (psig)	A	30	29	CO
C	Pressure S1: MINIMUM alarm value	-1	-20 (-290)	Pressure S1: MAXIMUM alarm value	barg (psig)	A	39	38	CO
C	Pressure S1: MAXIMUM alarm value	9.3	Pressure S1: MINIMUM alarm value	200 (2900)	barg (psig)	A	37	36	CO
C	S2: calibration offset	0	-20 (-36), -20	20 (36), 20	°C (°F), volt	A	41	40	CO

user *	Parameter/description	Def.	Min.	Max.	UOM	Type **	CAREL SVP	Modbus®	Note
C	S2: calibration gain, 0 to 10 V	1	-20	20	-	A	43	42	CO
C	Temperature S2: MINIMUM alarm value	-50	-60 (-76)	Temperature S2: MAXIMUM alarm value	°C (°F)	A	46	45	CO
C	Temperature S2: MAXIMUM alarm value	105	Temperature S2: MINIMUM alarm value	200 (392)	°C (°F)	A	44	43	CO
C	S3: calibration offset	0	-60 (-870)	60 (870)	barg (psig)	A	35	34	CO
C	S3: calibration gain, 4 to 20 mA	1	-20	20	-	A	82	81	CO
C	Pressure S3 : MINIMUM value	-1	-20 (-290)	Pressure S3: MAXIMUM value	barg (psig)	A	33	32	CO
C	Pressure S3: MAXIMUM value	9.3	Pressure S3: MINIMUM value	200 (2900)	barg (psig)	A	31	30	CO
C	Pressure S3: MINIMUM alarm value	-1	-20 (-290)	Pressure S3: MAXIMUM alarm value	barg (psig)	A	40	39	CO
C	Pressure S3: MAXIMUM alarm value	9.3	Pressure S3: MINIMUM alarm value	200 (2900)	barg (psig)	A	38	37	CO
C	S4: calibration offset	0	-20 (-36)	20 (36)	°C (°F)	A	42	41	CO
C	Temperature S4: MINIMUM alarm value	-50	-60 (-76)	Temperature S4: MAXIMUM alarm value	°C (°F)	A	47	46	CO
C	Temperature S4: MAXIMUM alarm value	105	Temperature S4: MINIMUM alarm value	200 (392)	°C (°F)	A	45	44	CO
CONTROL									
A	Superheat set point	11	LowSH: threshold	180 (324)	K (°F)	A	50	49	-
A	Valve opening at start-up (evaporator/valve capacity ratio)	50	0	100	%	I	37	164	-
C	Valve open in standby (0= disabled= valve closed; 1= enabled= valve open 25%)	0	0	1	-	D	23	22	-
C	Start delay after defrost - CANNOT BE SELECTED	10	0	60	min	I	40	167	-
A	Pre-position time	6	0	18000	s	I	90	217	-
A	Hot gas bypass temperature set point	10	-60 (-76)	200 (392)	°C (°F)	A	28	27	-
A	Hot gas bypass pressure set point	3	-20 (-290)	200 (2900)	barg (psig)	A	62	61	-
A	EPR pressure set point	3.5	-20 (-290)	200 (2900)	barg (psig)	A	29	28	-
C	PID: proportional gain	15	0	800	-	A	48	47	-
C	PID: integral time	150	0	1000	s	I	38	165	-
C	PID: derivative time	5	0	800	s	A	49	48	-
A	LowSH protection: threshold	5	-40 (-72)	SH set point	K (°F)	A	56	55	-
C	LowSH protection: integral time	15	0	800	s	A	55	54	-
A	LOP protection: threshold	-50	-60 (-76)	MOP protection: threshold	°C (°F)	A	52	51	-
C	LOP protection: integral time	0	0	800	s	A	51	50	-
A	MOP protection: threshold	50	LOP protection: threshold	200 (392)	°C (°F)	A	54	53	-
C	MOP protection: integral time	20	0	800	s	A	53	52	-
A	Enable manual valve positioning	0	0	1	-	D	24	23	-
A	Manual valve position	0	0	9999	step	I	39	166	-
C	Discharge superheat setpoint (CANNOT BE SELECTED)	35	-40(-72)	180 (324)	K (F°)	A	100	99	-
C	Discharge temperature setpoint (CANNOT BE SELECTED)	105	-60(-76)	200 (392)	°C (°F)	A	101	100	-
SPECIAL									
A	HiTcond: threshold - CANNOT BE SELECTED	80	-60 (-76)	200 (392)	°C (°F)	A	58	57	-
C	HiTcond: integral time - CANNOT BE SELECTED	20	0	800	s	A	57	56	-
A	Modulating thermostat: set point - CANNOT BE SELECTED	0	-60 (-76)	200 (392)	°C (°F)	A	61	60	-
A	Modulating thermostat: differential - CANNOT BE SELECTED	0.1	0.1 (0.2)	100 (180)	°C (°F)	A	60	59	-
C	Mod. thermostat: SH set point offset - CANNOT BE SELECTED	0	0 (0)	100 (180)	K (°F)	A	59	58	-
C	Coefficient 'A' for CO ₂ control	3.3	-100	800	-	A	63	62	-
C	Coefficient 'B' for CO ₂ control	-22.7	-100	800	-	A	64	63	-
C	Force manual tuning 0=no; 1= yes	0	0	1	-	D	39	38	-
C	Tuning method 0 to 100= automatic selection 101 to 141= manual selection 142 to 254= not allowed 255= PID parameters model identified	0	0	255	-	I	79	206	-
C	Network settings 0= 4800 1= 9600 2= 19200	2	0	2	bit/s	I	74	201	CO
A	Power supply mode 0= 24 Vac; 1= 24 Vdc	0	0	1	-	D	47	46	CO

user *	Parameter/description	Def.	Min.	Max.	UOM	Type **	CAREL SVP	Modbus®	Note
ALARM CONFIGURATION									
C	Low superheat alarm delay (LowSH) (0= alarm disabled)	300	0	18000	s	I	43	170	-
C	Low evaporation temperature alarm delay (LOP) (0= alarm disabled)	300	0	18000	s	I	41	168	-
C	High evaporation temperature alarm delay (MOP) (0= alarm disabled)	600	0	18000	s	I	42	169	-
C	High condensing temperature alarm delay (HiTcond) CANNOT BE SELECTED	600	0	18000	s	I	44	171	-
C	Low suction temperature alarm threshold	-50	-60 (-76)	200 (392)	°C (°F)	A	26	25	-
C	Low suction temperature alarm delay (0= alarm disabled)	300	0	18000	s	I	9	136	-
VALVE									
C	EEV minimum steps	50	0	9999	step	I	30	157	-
C	EEV maximum steps	480	0	9999	step	I	31	158	-
C	EEV closing steps	500	0	9999	step	I	36	163	-
C	EEV rated speed	50	1	2000	step/s	I	32	159	-
C	EEV rated current	450	0	800	mA	I	33	160	-
C	EEV holding current	100	0	250	mA	I	35	162	-
C	EEV duty cycle	30	1	100	%	I	34	161	-
C	Synchronise position in opening	1	0	1	-	D	20	19	-
C	Synchronise position in closing	1	0	1	-	D	21	20	-

Tab. 8.a

* User level: A= Service (installer), C= manufacturer.

** Type of variable: A= Analogue; D= Digital; I= Integer

CO= parameter settable from driver A or from driver B

8.2 Table of parameters, driver B

user *	Parameter/description	Def.	Min.	Max.	UOM	Type **	CAREL SVP	Modbus®	Note
CONFIGURATION									
A	Network address	pLAN: 30 altri: 198	1	207	-	I	11	138	CO
A	Refrigerant: 1= R22 2= R134a 3= R404A 4= R407C 5= R410A 6= R507A 7= R290 8= R600 9= R600a 10= R717 11= R744 12= R728 13= R1270 14= R417A 15= R422D 16= R413A 17= R422A 18= R423A 19= R407A 20= R427A 21= R245Fa 22= R407F	R404A	-	-	-	I	55	182	-
A	Valve: 1= CAREL E ^V 2= Alco EX4 3= Alco EX5 4= Alco EX6 5= Alco EX7 6= Alco EX8 330 Hz recommended CAREL 7= Alco EX8 500 Hz specific Alco 8= Sporlan SEI 0.5-11 9= Sporlan SER 1.5-20 10= Sporlan SEI 30 11= Sporlan SEI 50 12= Sporlan SEH 100 13= Sporlan SEH 175 14= Danfoss ETS 12.5-25B 15= Danfoss ETS 50B 16= Danfoss ETS 100B 17= Danfoss ETS 250 18= Danfoss ETS 400 19= two CAREL E ^V connected together 20= Sporlan SER(I)G, J, K 21= Danfoss CCM 10-20-30 22= Danfoss CCM 40	CAREL E ^V	-	-	-	I	54	181	
A	Probe S1: Ratiometric (OUT=0 to 5 V) Electronic (OUT=4 - 20 mA) 1= -1 to 4.2 barg 8= -0.5 to 7 barg 2= 0.4 to 9.3 barg 9= 0 to 10 barg 3= -1 to 9.3 barg 10= 0 to 18.2 bar 4= 0 to 17.3 barg 11= 0 to 25 barg 5= 0.85 to 34.2 barg 12= 0 to 30 barg 6= 0 to 34.5 barg 13= 0 to 44.8 barg 7= 0 to 45 barg 14= remote, -0.5 to 7 barg 15= remote, 0 to 10 barg 16= remote, 0 to 18.2 barg 17= remote, 0 to 25 barg 18= remote, 0 to 30 barg 19= remote, 0 to 44.8 barg 20= 4 to 20mA external signal 21= -1 to 12.8 barg 22= 0 to 20.7 barg 23= 1.86 to 43.0 barg	Ratiometric: -1 to 9.3 barg	-	-	-	I	16	143	CO

user *	Parameter/description	Def.	Min.	Max.	UOM	Type **	CAREL SVP	Modbus®	Note
A	Main control: 1= Multiplexed showcase/cold room 2= Showcase/cold room with compressor on board 3= "Perturbed" showcase/cold room 4= Showcase/cold room with sub-critical CO ₂ 5= R404A condenser for sub-critical CO ₂ 6= Air-conditioner/chiller with plate heat exchanger 7= Air-conditioner/chiller with tube bundle heat exchanger 8= Air-conditioner/chiller with finned coil heat exchanger 9= Air-conditioner/chiller with variable cooling capacity 10= "Perturbed" air-conditioner/chiller 11= EPR back pressure 12= Hot gas bypass by pressure 13= Hot gas bypass by temperature 14= Transcritical CO ₂ gas cooler 15= Analogue positioner (4 to 20 mA) 16= Analogue positioner (0 to 10 V) 17= Air-conditioner/chiller or showcase/cold room with adaptive control 18= Air-conditioner/chiller with Digital Scroll compressor 19= AC or chiller with SIAM ANB scroll compressor (CANNOT BE SELECTED) 20= superheat regulation with 2 temperature probes (CANNOT BE SELECTED) 21= I/O expander for pCO (*) (*)= control only settable on driver A, however corresponds to the entire controller	Multiplexed showcase/cold room	-	-	-	I	56	183	-
A	Probe S2: 1= CAREL NTC 2= CAREL NTC-HT hi temp. 3= Combined NTC SPKP**T0 4= 0 to 10 V external signal	CAREL NTC	-	-	-	I	17	144	CO
A	Auxiliary control: Disabled (NOT MODIFIABLE)	-	-	-	-	I	18	145	CO
A	Probe S3: Ratiometric (OUT=0 to 5 V) Electronic (OUT=4 - 20 mA) 1= -1 to 4.2 barg 8= -0.5 to 7 barg 2= 0.4 to 9.3 barg 9= 0 to 10 barg 3= -1 to 9.3 barg 10= 0 to 18.2 barg 4= 0 to 17.3 barg 11= 0 to 25 barg 5= 0.85 to 34.2 barg 12= 0 to 30 barg 6= 0 to 34.5 barg 13= 0 to 44.8 barg 7= 0 to 45 barg 14= remote, -0.5 to 7 barg 15= remote, 0 to 10 barg 16= remote, 0 to 18.2 barg 17= remote, 0 to 25 barg 18= remote, 0 to 30 barg 19= remote, 0 to 44.8 barg 20= 4 to 20mA external signal 21= -1 to 12.8 barg 22= 0 to 20.7 barg 23= 1.86 to 43.0 barg	Ratiometric: -1 to 9.3 barg	-	-	-	I	19	146	CO
A	Relay configuration: 1= Disabled 2= Alarm relay (open when alarm active) 3= Solenoid valve relay (open in standby) 4= Valve + alarm relay (open in standby and control alarms) 5= Reversed alarm relay (closed in case of alarm) 6= Valve status relay (open if valve is closed)	Alarm relay	-	-	-	I	57	184	-
A	Probe S4: 1= CAREL NTC 2= CAREL NTC-HT high temperature 3= Combined NTC SPKP**T0	CAREL NTC	-	-	-	I	20	147	CO
A	DI2 Configuration: 1= Disabled 2= Valve regulation optimization after defrost 3= Discharged battery alarm management 4= Valve forced open (at 100%) 5= Regulation start/stop 6= Regulation backup 7= Regulation security	Regulation start/stop (tLAN-RS485) / Regulation backup (pLAN)	-	-	-	I	10	137	CO

user*	Parameter/description	Def.	Min.	Max.	UOM	Type**	CAREL SVP	Modbus®	Note
C	Variable 1 on display: 1= Valve opening 2= Valve position 3= Current cooling capacity 4= Set point control 5= Superheat 6= Suction temperature 7= Evaporation temperature 8= Evaporation pressure 9= Condensing temperature 10= Condensing pressure 11= Modulating thermostat temperature(*) 12= EPR pressure 13= Hot gas bypass pressure 14= Hot gas bypass temperature 15= CO ₂ gas cooler outlet temperature 16= CO ₂ gas cooler outlet pressure 17= CO ₂ gas cooler pressure set point 18= Probe S1 reading 19= Probe S2 reading 20= Probe S3 reading 21= Probe S4 reading 22= 4 to 20 mA input 23= 0 to 10 V input (*) CANNOT BE SELECTED	Superheat	-	-	-	I	58	185	-
C	Variable 2 on display (see variable 1 on display)	Valve opening	-	-	-	I	59	186	-
C	Probe S1 alarm management: 1= No action 2= Forced valve closing 3= Valve in fixed position 4= Use backup probe S3 (*) (*) CANNOT BE SELECTED	Valve in fixed position	-	-	-	I	24	151	CO
C	Probe S2 alarm management: 1= No action 2= Forced valve closing 3= Valve in fixed position 4= Use backup probe S4 (*) (*) CANNOT BE SELECTED	Valve in fixed position	-	-	-	I	25	152	CO
C	Probe S3 alarm management: 1= No action 2= Forced valve closing 3= Valve in fixed position	No action	-	-	-	I	26	153	CO
C	Probe S4 alarm management: 1= No action 2= Forced valve closing 3= Valve in fixed position	No action	-	-	-	I	27	154	CO
C	Unit of measure: 1= °C/K/barg; 2= °F/psig	°C/K/barg	-	-	-	I	21	148	CO
A	DI1 configuration 1= Disabled 2= Valve regulation optimization after defrost 3= Discharged battery alarm management 4= Valve forced open (at 100%) 5= Regulation start/stop 6= Regulation backup 7= Regulation security	Regulation start/stop (tLAN-RS485) / Regulation backup (pLAN)	-	-	-	I	85	212	CO
C	Language: Italiano; English	Italiano	-	-	-	-	-	-	CO
PROBES									
C	S1: calibration offset	0	-60 (-870), -60	60 (870), 60	barg (psig) mA	A	34	33	CO
C	S1: calibration gain, 4 to 20 mA	1	-20	20	-	A	36	35	CO
C	Pressure S1: MINIMUM value	-1	-20 (-290)	Pressure S1: MAXIMUM value	barg (psig)	A	32	31	CO
C	Pressure S1: MAXIMUM value	9.3	Pressure S1: MINIMUM value	200 (2900)	barg (psig)	A	30	29	CO
C	Pressure S1: MINIMUM alarm value	-1	-20 (-290)	Pressure S1: MAXIMUM alarm value	barg (psig)	A	39	38	CO
C	Pressure S1: MAXIMUM alarm value	9.3	Pressure S1: MINIMUM alarm value	200 (2900)	barg (psig)	A	37	36	CO
C	S2: calibration offset	0	-20 (-36), -20	20 (36), 20	°C (°F), volt	A	41	40	CO

user*	Parameter/description	Def.	Min.	Max.	UOM	Type**	CAREL SVP	Modbus®	Note
C	S2: calibration gain, 0 to 10 V	1	-20	20	-	A	43	42	CO
C	Temperature S2: MINIMUM alarm value	-50	-60 (-76)	Temperature S2: MAXIMUM alarm value	°C (°F)	A	46	45	CO
C	Temperature S2: MAXIMUM alarm value	105	Temperature S2: MINIMUM alarm value	200 (392)	°C (°F)	A	44	43	CO
C	S3: calibration offset	0	-60 (-870)	60 (870)	barg (psig)	A	35	34	CO
C	S3: calibration gain, 4 to 20 mA	1	-20	20	-	A	82	81	CO
C	Pressure S3 : MINIMUM value	-1	-20 (-290)	Pressure S3: MAXIMUM value	barg (psig)	A	33	32	CO
C	Pressure S3: MAXIMUM value	9.3	Pressure S3: MINIMUM value	200 (2900)	barg (psig)	A	31	30	CO
C	Pressure S3: MINIMUM alarm value	-1	-20 (-290)	Pressure S3: MAXIMUM alarm value	barg (psig)	A	40	39	CO
C	Pressure S3: MAXIMUM alarm value	9.3	Pressure S3: MINIMUM alarm value	200 (2900)	barg (psig)	A	38	37	CO
C	S4: calibration offset	0	-20 (-36)	20 (36)	°C (°F)	A	42	41	CO
C	Temperature S4: MINIMUM alarm value	-50	-60 (-76)	Temperature S4: MAXIMUM alarm value	°C (°F)	A	47	46	CO
C	Temperature S4: MAXIMUM alarm value	105	Temperature S4: MINIMUM alarm value	200 (392)	°C (°F)	A	45	44	CO
CONTROL									
A	Superheat set point	11	LowSH: threshold	180 (324)	K (°F)	A	83	82	-
A	Valve opening at start-up (evaporator/valve capacity ratio)	50	0	100	%	I	60	187	-
C	Valve open in standby (0= disabled= valve closed; 1= enabled= valve open 25%)	0	0	1	-	D	36	35	-
C	Start delay after defrost - CANNOT BE SELECTED	10	0	60	min	I	40	167	CO
A	Pre-position time	6	0	18000	s	I	90	217	-
A	Hot gas bypass temperature set point	10	-60 (-76)	200 (392)	°C (°F)	A	84	83	-
A	Hot gas bypass pressure set point	3	-20 (-290)	200 (2900)	barg (psig)	A	85	84	-
A	EPR pressure set point	3.5	-20 (-290)	200 (2900)	barg (psig)	A	86	85	-
C	PID: proportional gain	15	0	800	-	A	87	86	-
C	PID: integral time	150	0	1000	s	I	61	188	-
C	PID: derivative time	5	0	800	s	A	88	87	-
A	LowSH protection: threshold	5	-40 (-72)	SH set point	K (°F)	A	89	88	-
C	LowSH protection: integral time	15	0	800	s	A	90	89	-
A	LOP protection: threshold	-50	-60 (-76)	MOP protection: threshold	°C (°F)	A	91	90	-
C	LOP protection: integral time	0	0	800	s	A	92	91	-
A	MOP protection: threshold	50	LOP protection: threshold	200 (392)	°C (°F)	A	93	92	-
C	MOP protection: integral time	20	0	800	s	A	94	93	-
A	Enable manual valve positioning	0	0	1	-	D	32	31	-
A	Manual valve position	0	0	9999	step	I	53	180	-
C	Discharge superheat setpoint (CANNOT BE SELECTED)	35	-40(-72)	180 (324)	K (F°)	A	100	99	-
C	Discharge temperature setpoint (CANNOT BE SELECTED)	105	-60(-76)	200 (392)	°C (°F)	A	101	100	-
SPECIAL									
A	HiTcond: threshold - CANNOT BE SELECTED	80	-60 (-76)	200 (392)	°C (°F)	A	58	57	CO
C	HiTcond: integral time - CANNOT BE SELECTED	20	0	800	s	A	57	56	CO
A	Modulating thermostat: set point - CANNOT BE SELECTED	0	-60 (-76)	200 (392)	°C (°F)	A	61	60	CO
A	Modulating thermostat: differential - CANNOT BE SELECTED	0.1	0.1 (0.2)	100 (180)	°C (°F)	A	60	59	CO
C	Mod. thermostat: SH set point offset - CANNOT BE SELECTED	0	0 (0)	100 (180)	K (°F)	A	59	58	CO
C	Coefficient 'A' for CO ₂ control	3.3	-100	800	-	A	95	94	-
C	Coefficient 'B' for CO ₂ control	-22.7	-100	800	-	A	96	95	-
C	Force manual tuning 0=no; 1=yes	0	0	1	-	D	41	40	-
C	Tuning method 0 to 100= automatic selection 101 to 141= manual selection 142 to 254= not allowed 255= PID parameters model identified	0	0	255	-	I	80	207	-
C	Network settings 0= 4800 1= 9600 2= 19200	2	0	2	bit/s	I	74	201	CO
A	Power supply mode 0= 24 Vac; 1= 24 Vdc	0	0	1	-	D	47	46	CO

user*	Parameter/description	Def.	Min.	Max.	UOM	Type**	CAREL SVP	Modbus®	Note
ALARM CONFIGURATION									
C	Low superheat alarm delay (LowSH) (0= alarm disabled)	300	0	18000	s	I	62	189	-
C	Low evaporation temperature alarm delay (LOP) (0= alarm disabled)	300	0	18000	s	I	63	190	-
C	High evaporation temperature alarm delay (MOP) (0= alarm disabled)	600	0	18000	s	I	64	191	-
C	High condensing temperature alarm delay (HiTcond) CANNOT BE SELECTED	600	0	18000	s	I	44	171	-
C	Low suction temperature alarm threshold	-50	-60 (-76)	200 (392)	°C (°F)	A	97	96	-
C	Low suction temperature alarm delay (0= alarm disabled)	300	0	18000	s	I	65	192	-
VALVE									
C	EEV minimum steps	50	0	9999	step	I	66	193	-
C	EEV maximum steps	480	0	9999	step	I	67	194	-
C	EEV closing steps	500	0	9999	step	I	68	195	-
C	EEV rated speed	50	1	2000	step/s	I	69	196	-
C	EEV rated current	450	0	800	mA	I	70	197	-
C	EEV holding current	100	0	250	mA	I	71	198	-
C	EEV duty cycle	30	1	100	%	I	72	199	-
C	Synchronise position in opening	1	0	1	-	D	37	36	-
C	Synchronise position in closing	1	0	1	-	D	38	37	-

Tab. 8.b

* User level: A= Service (installer), C= manufacturer.

** Type of variable: A= Analogue; D= Digital; I= Integer

CO= parameter settable from driver A or from driver B

8.3 Unit of measure

In the configuration parameters menu, with access by manufacturer password, the user can choose the unit of measure for the driver:

- international system (°C, K, barg);
- imperial system (°F, psig).

 **Note:** the units of measure K and R relate to degrees Kelvin or Rankine adopted for measuring the superheat and the related parameters.

When changing the unit of measure, all the values of the parameters saved on the driver and all the measurements read by the probes will be recalculated. This means that when changing the units of measure, control remains unaltered.

Example 1: The pressure read is 100 barg, this will be immediately converted to the corresponding value of 1450 psig.

Example 2: The "superheat set point" parameter set to 10 K will be immediately converted to the corresponding value of 18 °F.

Example 3: The "Temperature S4: maximum alarm value" parameter, set to 150 °C, will be immediately converted to the corresponding value of 302 °F.

 **Note:** due to limits in the internal arithmetic of the driver, pressure values above 200 barg (2900 psig) and temperature values above 200 °C (392 °F) cannot be converted

8.4 Variables accessible via serial – driver A

	Description	Default	Min	Max	Type	CAREL SVP	Modbus®	R/W
	Probe S1 reading	0	-20 (-290)	200 (2900)	A	1	0	R
	Probe S2 reading	0	-60 (-870)	200 (2900)	A	2	1	R
	Probe S3 reading	0	-20 (-290)	200 (2900)	A	3	2	R
	Probe S4 reading	0	-60 (-76)	200 (392)	A	4	3	R
	Suction temperature	0	-60 (-76)	200 (392)	A	5	4	R
	Evaporation temperature	0	-60 (-76)	200 (392)	A	6	5	R
	Evaporation pressure	0	-20 (-290)	200 (2900)	A	7	6	R
	Hot gas bypass temperature	0	-60 (-76)	200 (392)	A	8	7	R
	EPR pressure (back pressure)	0	-20 (-290)	200 (2900)	A	9	8	R
	Superheat	0	-40 (-72)	180 (324)	A	10	9	R
	Condensing pressure	0	-20 (-290)	200 (2900)	A	11	10	R
	Condensing temperature	0	-60 (-76)	200 (392)	A	12	11	R
	Modulating thermostat temperature	0	-60 (-76)	200 (392)	A	13	12	R
	Hot gas bypass pressure	0	-20 (-290)	200 (2900)	A	14	13	R
	CO ₂ gas cooler outlet pressure	0	-20 (-290)	200 (2900)	A	15	14	R
	CO ₂ gas cooler outlet temperature	0	-60 (-76)	200 (392)	A	16	15	R
	Valve opening	0	0	100	A	17	16	R
	CO ₂ gas cooler pressure set point	0	-20 (-290)	200 (2900)	A	18	17	R
	4 to 20 mA input value (S1)	4	4	20	A	19	18	R
	0 to 10 V input value (S2)	0	0	10	A	20	19	R
	Control set point	0	-60 (-870)	200 (2900)	A	21	20	R
	Controller firmware version	0	0	800	A	25	24	R
	MOP: suction temperature threshold (S2)	30	-60 (-76)	200 (392)	A	102	101	R/W
	Valve position	0	0	9999	I	4	131	R
	Current unit cooling capacity	0	0	100	I	7	134	R/W
	Adaptive control status	-	0	10	I	75	202	R
	Last tuning result	0	0	8	I	76	203	R
	Extended measured probe S1 (*)	0	-2000 (-2901)	20000 (29007)	I	83	210	R
	Emergency closing speed valve A	150	1	2000	I	86	213	R/W
Alarms	Low suction temperature	0	0	1	D	1	0	R
	LAN error	0	0	1	D	2	1	R
	EEPROM damaged	0	0	1	D	3	2	R
	Probe S1	0	0	1	D	4	3	R
	Probe S2	0	0	1	D	5	4	R
	Probe S3	0	0	1	D	6	5	R
	Probe S4	0	0	1	D	7	6	R
	EEV motor error	0	0	1	D	8	7	R
	Status of relay A	0	0	1	D	9	8	R
PROTECT. ACTIVATED	LOP (low evaporation temperature)	0	0	1	I	50	49	R
	MOP high evaporation temperature)	0	0	1	I	51	50	R
	LowSH (low superheat)	0	0	1	I	52	51	R
	HITcond (high condensing temperature)	0	0	1	I	53	52	R
Alarms	LOP (low evaporation temperature)	0	0	1	D	10	9	R
	MOP (high evaporation temperature)	0	0	1	D	11	10	R
	LowSH (low superheat)	0	0	1	D	12	11	R
	Status of digital input DI1	0	0	1	D	14	13	R
	Status of digital input DI2	0	0	1	D	15	14	R
	Guided initial procedure completed	0	0	1	D	22	21	R/W
Alarm	Adaptive control ineffective	0	0	1	D	40	39	R
	Mains power failure	0	0	1	D	45	44	R
	Regulation backup from supervisor	0	0	1	D	46	45	R/W

Tab. 8.c

(*) The displayed variable is to be divided by 100, and allows us to appreciate the hundredth of a bar (psig).

8.5 Variables accessible via serial – driver B

	Description	Default	Min	Max	Type	CAREL SVP	Modbus®	R/W
	Suction temperature	0	-60 (-76)	200 (392)	A	69	68	R
	Evaporation temperature	0	-60 (-76)	200 (392)	A	70	69	R
	Evaporation pressure	0	-20 (-290)	200 (2900)	A	71	70	R
	Hot gas bypass temperature	0	-60 (-76)	200 (392)	A	74	73	R
	EPR pressure (back pressure)	0	-20 (-290)	200 (2900)	A	72	71	R
	Superheat	0	-40 (-72)	180 (324)	A	68	67	R
	Hot gas bypass pressure	0	-20 (-290)	200 (2900)	A	73	72	R
	CO ₂ gas cooler outlet pressure	0	-20 (-290)	200 (2900)	A	76	75	R
	CO ₂ gas cooler outlet temperature	0	-60 (-76)	200 (392)	A	75	74	R
	Valve opening	0	0	100	A	66	65	R
	CO ₂ gas cooler pressure set point	0	-20 (-290)	200 (2900)	A	77	76	R
	4 to 20 mA input value (S3)	4	4	20	A	78	77	R
	Control set point	0	-60 (-870)	200 (2900)	A	67	66	R
	MOP: suction temperature threshold (S4)	30	-60 (-76)	200 (392)	A	103	102	R/W
	Valve position	0	0	9999	I	49	176	R
	Current unit cooling capacity	0	0	100	I	50	177	R/W
	Last tuning result	0	0	8	I	78	205	R
	Adaptive control status	0	0	10	I	77	204	R
	Emergency closing speed valve B	150	1	2000	I	86	213	R/W
	Extended measured probe S3 (*)	0	-2000 (-2901)	20000 (29007)	I	84	211	R
Alarms	Low suction temperature	0	0	1	D	29	28	R
	EEV motor error	0	0	1	D	30	29	R
	Status of relay B	0	0	1	D	31	30	R
PROTECT. ACTIVATED	LOP (low evaporation temperature)	0	0	1	I	54	53	R
	MOP high evaporation temperature)	0	0	1	I	55	54	R
	LowSH (low superheat)	0	0	1	I	56	55	R
	HiTcond (high condensing temperature)	0	0	1	I	57	56	R
Alarms	LOP (low evaporation temperature)	0	0	1	D	27	26	R
	MOP (high evaporation temperature)	0	0	1	D	28	27	R
	LowSH (low superheat)	0	0	1	D	26	25	R
	Driver B disconnected	0	0	1	D	35	34	R
	Adaptive control ineffective	0	0	1	D	42	41	R
	Regulation backup from supervisor (driver B)	0	0	1	D	48	47	R/W

Tab. 8.d

(*) The displayed variable is to be divided by 100, and allows us to appreciate the hundredth of a bar (psig).

Type of variable: A= analogue; D= digital; I= integer

SVP= variable address with CAREL protocol on 485 serial card.

Modbus®: variable address with Modbus® protocol on 485 serial card.

8.6 Variables used based on the type of control

The table below shows the variables used by the drivers depending on the "Main control" parameter. At the end of the variable list are the screens used to check the probe and valve electrical connections for driver A and driver B. These variables are visible on the display by accessing display mode (see paragraph 3.4) and via serial connection with VPM, PlantVisorPRO,... (see paragraphs 8.4, 8.5)

Procedure for showing the variables on the display:

- press the Help and Enter buttons together to select driver A or B;
- press the UP/DOWN button;
- press the DOWN button to move to the next variable/screen;
- press the Esc button to return to the standard display.

Variable displayed	Main control						
	Superheat control	Transcritical CO ₂	Gas bypass temperature	Gas bypass pressure	EPR back pressure	Analogue positioning	I/O expander for pCO
Valve opening (%)	•	•	•	•	•	•	•
Valve position (step)	•	•	•	•	•	•	•
Current unit cooling capacity	•	•	•	•	•	•	•
Set point control	•	•		•			
Superheat	•						
Suction temperature	•						
Evaporation temperature	•						
Evaporation pressure	•						
Condensing temperature (*)							
Condensing pressure (*)							
Modulating thermostat temperature(*)							
EPR pressure (back pressure)					•		
Hot gas bypass pressure				•			
Hot gas bypass temperature			•				
CO ₂ gas cooler outlet temperature		•					
CO ₂ gas cooler outlet pressure		•					
CO ₂ gas cooler pressure set point		•					
Probe S1 reading	•	•	•	•	•	•	•
Probe S2 reading	•	•	•	•	•	•	•
Probe S3 reading	•	•	•	•	•	•	•
Probe S4 reading	•	•	•	•	•	•	•
4 to 20 mA input value						•	•
0 to 10V input value						•	•
Status of digital input DI1 (**)	•	•	•	•	•	•	•
Status of digital input DI2 (**)	•	•	•	•	•	•	•
EVD firmware version	•	•	•	•	•	•	•
Display firmware version	•	•	•	•	•	•	•
Adaptive control status 0= not enabled or stopper 1= monitoring superheat 2= monitoring suction temperature 3= wait superheat stabilisation 4= wait suction temperature stabilisation 5= applying step 6= positioning valve 7= sampling response to step 8= wait stabilisation in response to step 9= wait tuning improvement 10= stop, max number of attempts exceeded	•						
Last tuning result 0= no attempt performed 1= attempt interrupted 2= step application error 3= time constant/delay error 4= model error 5= tuning ended successfully on suction temperature 6= tuning ended successfully on superheat	•						

Tab. 8.e

(*) The value of the variable is not displayed

(**) Status of digital input: 0= open, 1= closed.

 **Note:** the readings of probes S1, S2, S3, S4 is always displayed, regardless of whether or not the probe is connected

9. ALARMS

9.1 Alarms

There are two types of alarms for each driver:

- system: valve motor, EEPROM, probe and communication;
- control: low superheat, LOP, MOP, low suction temperature.

The activation of the alarms depends on the setting of the threshold and activation delay parameters. Setting the delay to 0 disables the alarms. The EEPROM alarm always shuts down the controller.

All the alarms are reset automatically, once the causes are no longer present. The alarm relay contact will open if the relay is configured as alarm relay using the corresponding parameter. The signalling of the alarm event on the driver depends on whether the LED board or the display board is fitted, as shown in the table below.

Note: the alarm LED only comes on for the system alarms, and not for the control alarms.

Example: display system alarm on LED board for driver A and for driver B

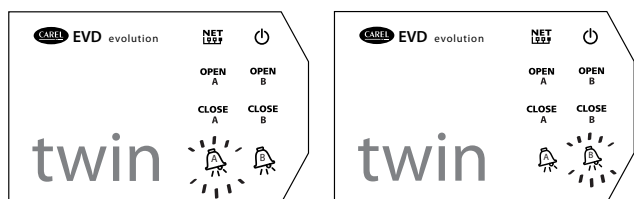

Fig. 9.a

Note: the alarm LED comes on to signal a mains power failure only if the EVBAT*** module (accessory) has been connected, guaranteeing the power required to close the valve.

The display shows both types of alarms, in two different modes:

system alarm: on the main page, the ALARM message is displayed, flashing. Pressing the Help button displays the description of the alarm and, at the top right, the total number of active alarms and the driver where the alarm occurred (A / B). The same alarm may occur on both drivers (e.g. probe alarm)

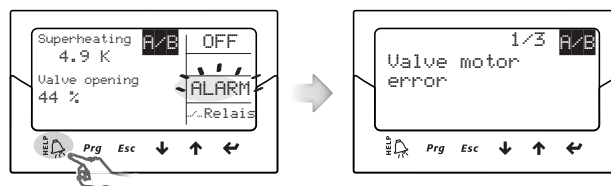

Fig. 9.b

- **control alarm:** next to the flashing ALARM message, the main page shows the type of protector activated.

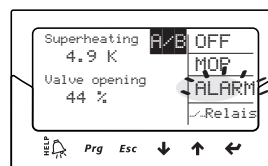

Fig. 9.c

- Note:**
- to display the alarm queue, press the Help button and scroll using the UP/DOWN buttons. If at the end of the alarms for driver A/B the following message is shown:

Alarms active on driver B/A

1. press Esc to return to the standard display;
 2. press the Help and Enter buttons together to move to the corresponding driver;
 3. press Help to display the required alarm queue.
- the control alarms can be disabled by setting the corresponding delay to zero.

Table of alarms

Type of alarm	Cause of the alarm	LED	Display	Relay	Reset	Effects on control	Checks/ solutions
Probe S1	Probe S1 faulty or exceeded set alarm range	red alarm LED	ALARM flashing	Depends on configuration parameter	automatic	Depends on parameter "Probe S1 alarm management"	Check the probe connections. Check the "Probe S1 alarm management", & "Pressure S1: MINIMUM & MAXIMUM alarm value" parameters
Probe S2	Probe S2 faulty or exceeded set alarm range	red alarm LED	ALARM flashing	Depends on configuration parameter	automatic	Depends on parameter "Probe S2 alarm management"	Check the probe connections. Check the "Probe S2 alarm management", & "Temperature S2: MINIMUM & MAXIMUM alarm value" parameters
Probe S3	Probe S3 faulty or exceeded set alarm range	red alarm LED	ALARM flashing	Depends on configuration parameter	automatic	Depends on parameter "Probe S3 alarm management"	Check the probe connections. Check the "Probe S3 alarm management", & "Pressure S3: MINIMUM & MAXIMUM alarm value" parameters
Probe S4	Probe S4 faulty or exceeded set alarm range	red alarm LED	ALARM flashing	Depends on configuration parameter	automatic	Depends on parameter "Probe S4 alarm management"	Check the probe connections. Check the "Probe S4 alarm management", & "Temperature S4: MINIMUM & MAXIMUM alarm value"
LowSH (low superheat)	LowSH protection activated	-	ALARM flashing & LowSH	Depends on configuration parameter	automatic	Protection action already active	Check the "LowSH protection: threshold & alarm delay" parameters
LOP (low evaporation temperature)	LOP protection activated	-	ALARM flashing & LOP	Depends on configuration parameter	automatic	Protection action already active	Check the "Protection LOP: threshold & alarm delay" parameters
MOP (high evaporation temperature)	MOP protection activated	-	ALARM flashing & MOP	Depends on configuration parameter	automatic	Protection action already active	Check the "MOP protection: threshold & alarm delay" parameters
Low suction temperature	Threshold and delay time exceeded	-	ALARM flashing	Depends on configuration parameter	automatic	No effect	Check the threshold and delay parameters.

Type of alarm	Cause of the alarm	LED	Display	Relay	Reset	Effects on control	Checks/ solutions
EEPROM damaged	EEPROM for operating and/or unit parameters damaged	red alarm LED	ALARM flashing	Depends on configuration parameter	Replace controller/ Contact service	Total shutdown	Replace the controller/Contact service
EEV motor error	Valve motor fault, not connected	red alarm LED	ALARM flashing	Depends on configuration parameter	automatic	Interruption	Check the connections and the condition of the motor. Switch controller off and on again
LAN error	LAN network communication error	green NET LED flashing	ALARM flashing	Depends on configuration parameter	automatic	Control based on DI1/DI2	Check the network address settings
	LAN network connection error	NET LED off	ALARM flashing	Depends on configuration parameter	automatic	Control based on DI1/DI2	Check the connections and that the pCO is on and working
Display connection error	No communication between controller and display	-	ERROR message	No change	Replace controller/ display	No effect	Check the controller/display and connectors
Driver B disconnected	Connection error, driver B	red alarm LED B	ALARM flashing	Depends on configuration parameter	automatic	Driver B: forced closing Driver A: no effect	Replace the controller
Alarms active on driver A (1)	Generic error, driver A	red alarm LED A	ALARM flashing	No change	automatic	No effect	See list of alarms for driver A
Alarms active on driver B (2)	Generic error, driver B	red alarm LED B	ALARM flashing	No change	automatic	No effect	See list of alarms for driver B
Adaptive control ineffective	Tuning failed	-	ALARM flashing	No change	automatic	No effect	Change "Main control" parameter setting
Wrong power supply mode (*)	DC driver power supply with "Power supply mode" parameter set to AC power supply	Green POWER LED flashing Red alarm LED	-	Depends on the configuration parameter	Change "Power supply mode" parameter setting	Total shutdown	Check the "Power supply mode" parameter and power supply

Tab. 9.a

1) Message that appears at the end of the list of alarms for driver B.
 (2) Message that appears at the end of the list of alarms for driver A.
 (*) In the event of AC power supply with "Power supply mode" set to DC, no alarm is displayed

9.2 Alarm relay configuration

The relay contacts are open when the controller is not powered. During normal operation, the relay can be disabled (and thus will be always open) or configured as:

- alarm relay : during normal operation, the relay contact is closed, and opens when any alarm is activated. It can be used to switch off the compressor and the system in the event of alarms.
- solenoid valve relay : during normal operation, the relay contact is closed, and is open only in standby. There is no change in the event of alarms.
- solenoid valve relay + alarm : during normal operation, the relay contact is closed, and opens in standby and/or for LowSH, MOP, HiTcond and low suction temperature alarms. This is because following such alarms, the user may want to protect the unit by stopping the flow of refrigerant or switching off the compressor. The LOP alarm is excluded, as in the event of low evaporation temperature closing the solenoid valve would worsen the situation.

Parameter/description	Def.
Relay configuration: 1= Disabled 2= Alarm relay (open when alarm active) 3= Solenoid valve relay (open in standby) 4= Valve + alarm relay (open in standby and control alarms) 5= Reversed alarm relay (closed in case of alarm) 6= Valve status relay (open if valve is closed)	Alarm relay

Tab. 9.b

9.3 Probe alarms

The probe alarms are part of the system alarms. When the value measured by one of the probes is outside of the field defined by the parameters corresponding to the alarm limits, an alarm is activated. The limits can be set independently of the range of measurement. Consequently, the field outside of which the alarm is signalled can be restricted, to ensure greater safety of the controlled unit.



Note:

- the alarm limits can also be set outside of the range of measurement, to avoid unwanted probe alarms. In this case, the correct operation of the unit or the correct signalling of alarms will not be guaranteed;
- by default, after having selected the type of probe used, the alarm limits will be automatically set to the limits corresponding to the range of measurement of the probe.

Parameter/description	Def.	Min.	Max.	UOM
Probes				
Pressure S1: MINIMUM alarm value (S1_AL_MIN)	-1	-20 (-290)	S1_AL_MAX	barg (psig)
Pressure S1: MAXIMUM alarm value (S1_AL_MAX)	9.3	S1_AL_MIN	200 (2900)	barg (psig)
Temperature S2: MINIMUM alarm value (S2_AL_MIN)	-50	-60 (-76)	S2_AL_MAX	°C (°F)
Temperature S2: MAXIMUM alarm value (S2_AL_MAX)	105	S2_AL_MIN	200 (392)	°C (°F)
Pressure S3: MINIMUM alarm value (S3_AL_MIN)	-1	-20 (-290)	S3_AL_MAX	barg (psig)
Pressure S3: MAXIMUM alarm value (S3_AL_MAX)	9.3	S3_AL_MIN	200 (2900)	barg (psig)
Temperature S4: MINIMUM alarm value (S4_AL_MIN)	-50	-60 (-76)	S4_AL_MAX	°C (°F)
Temperature S4: MAXIMUM alarm value (S4_AL_MAX)	105	S4_AL_MIN	200 (392)	°C (°F)

Tab. 9.c

The behaviour of the driver in response to probe alarms can be configured, using the manufacturer parameters. The options are:

- no action (control continues but the correct measurement of the variables is not guaranteed);
- forced closing of the valve (control stopped);
- valve forced to the initial position (control stopped).

Parameter/description	Def.	Min.	Max.	UOM
CONFIGURATION				
Probe S1 alarm management: 1= No action 2= Forced valve closing 3= Valve in fixed position 4= Use backup probe S3 (*) (*)= CANNOT BE SELECTED	Valve in fixed position	-	-	-
Probe S2 alarm management: 1= No action 2= Forced valve closing 3= Valve in fixed position 4= Use backup probe S4 (*) (*)= CANNOT BE SELECTED	Valve in fixed position	-	-	-
Probe S3 alarm management: 1= No action 2= Forced valve closing 3= Valve in fixed position	No action	-	-	-
Probe S4 alarm management: 1= No action 2= Forced valve closing 3= Valve in fixed position	No action	-	-	-
CONTROL				
Valve opening at start-up (evaporator/valve capacity ratio)	50	0	100	%

Tab. 9.d

9.4 Control alarms

These are alarms that are only activate during control.

Protector alarms

The alarms corresponding to the LowSH, LOP and MOP protectors are only activated during control when the corresponding activation threshold is exceeded, and only when the delay time defined by the corresponding parameter has elapsed. If a protector is not enabled (integral time= 0 s), no alarm will be signalled. If before the expiry of the delay, the protector control variable returns back inside the corresponding threshold, no alarm will be signalled.

 **Note:** this is a likely event, as during the delay, the protection function will have an effect.

If the delay relating to the control alarms is set to 0 s, the alarm is disabled. The protectors are still active, however. The alarms are reset automatically.

Low suction temperature alarm

The low suction temperature alarm is not linked to any protection function. It features a threshold and a delay, and is useful in the event of probe or valve malfunctions to protect the compressor using the relay to control the solenoid valve or to simply signal a possible risk.

In fact, the incorrect measurement of the evaporation pressure or incorrect configuration of the type of refrigerant may mean the superheat calculated is much higher than the actual value, causing an incorrect and excessive opening of the valve.

A low suction temperature measurement may in this case indicate the probable flooding of the compressor, with corresponding alarm signal.

If the alarm delay is set to 0 s, the alarm is disabled. The alarm is reset automatically, with a fixed differential of 3°C above the activation threshold.

Relay activation for control alarms

As mentioned in the paragraph on the configuration of the relay, in the event of LowSH, MOP and low suction temperature alarms, the driver relay will open both when configured as an alarm relay and configured as a solenoid + alarm relay.

In the event of LOP alarms, the driver relay will only open if configured as an alarm relay.

Parameter/Description	Def.	Min.	Max.	UOM
CONTROL				
LowSH protection: threshold	5	-40 (-72)	SH set point	K (°F)
LowSH protection: integral time	15	0	800	s
LOP protection: threshold	-50	-60 (-76)	MOP: threshold	°C (°F)
LOP protection: integral time	0	0	800	s
MOP protection: threshold	50	LOP: threshold	200 (392)	°C (°F)
MOP protection: integral time	20	0	800	s
ALARM CONFIGURATION				
Low superheat alarm delay (LowSH) (0= alarm disabled)	300	0	18000	s
Low evaporation temperature alarm delay (LOP) (0= alarm disabled)	300	0	18000	s
High evaporation temperature alarm delay (MOP) (0= alarm disabled)	600	0	18000	s
Low suction temperature alarm threshold	-50	-60 (-76)	200 (392)	°C (°F)
Low suction temperature alarm delay	300	0	18000	s

Tab. 9.e

9.5 EEV motor alarm

At the end of the commissioning procedure and whenever the controller is powered up, the valve motor error recognition procedure is activated. This precedes the forced closing procedure and lasts around 10 s. The valve is kept stationary to allow any valve motor faults or missing or incorrect connections to be detected. In any of these cases, the corresponding alarm is activated, with automatic reset. The controller will go into wait status, as it can longer control the valve. The procedure can be avoided by keeping the respective digital input closed for each driver. In this case, after having powered up the controller, forced closing of the valve is performed immediately.

 **Important:** after having resolved the problem with the motor, it is recommended to switch the controller off and on again to realign the position of the valve. If this is not possible, the automatic procedure for synchronising the position may help solve the problem, nonetheless correct control will not be guaranteed until the next synchronisation.

9.6 LAN error alarm

If the connection to the LAN network is offline for more than 6s due to an electrical problem, the incorrect configuration of the network addresses or the malfunction of the pCO controller, a LAN error alarm will be signalled.

The LAN error affects the operation of the controller as follows:

- **case 1:** unit in standby, digital input DI1/DI2 disconnected; driver A/B will remain permanently in standby and control will not be able to start;
- **case 2:** unit in control, digital input DI1/DI2 disconnected: the driver will stop control and will go permanently into standby;
- **case 3:** unit in standby, digital input DI1/DI2 connected: the driver will remain in standby, however control will be able to start if the digital input is closed. In this case, it will start with "current cooling capacity"= 100%;
- **case 4:** unit in control, digital input DI1/DI2 connected: driver A/B will remain in control status, maintaining the value of the "current cooling capacity". If the digital input opens, the driver will go to standby and control will be able to start again when the input closes. In this case, it will start with "current cooling capacity"= 100%.

10. TROUBLESHOOTING

The following table lists a series of possible malfunctions that may occur when starting and operating the driver and the electronic valve. These cover the most common problems and are provided with the aim of offering an initial response for resolving the problem.

PROBLEM	CAUSE	SOLUTION
The superheat value measured is incorrect	The probe does not measure correct values	Check that the pressure and the temperature measured are correct and that the probe position is correct. Check that the minimum and maximum pressure parameters for the pressure transducer set on the driver correspond to the range of the pressure probe installed. Check the correct probe electrical connections.
	The type of refrigerant set is incorrect	Check and correct the type of refrigerant parameter.
Liquid returns to the compressor during control	The type of valve set is incorrect	Check and correct the type of valve parameter.
	The valve is connected incorrectly (rotates in reverse) and is open	Check the movement of the valve by placing it in manual control and closing or opening it completely. One complete opening must bring a decrease in the superheat and vice-versa. If the movement is reversed, check the electrical connections.
	The superheat set point is too low	Increase the superheat set point. Initially set it to 12 °C and check that there is no longer return of liquid. Then gradually reduce the set point, always making sure there is no return of liquid.
	Low superheat protection ineffective	If the superheat remains low for too long with the valve that is slow to close, increase the low superheat threshold and/or decrease the low superheat integral time. Initially set the threshold 3 °C below the superheat set point, with an integral time of 3-4 seconds. Then gradually lower the low superheat threshold and increase the low superheat integral time, checking that there is no return of liquid in any operating conditions.
	Stator broken or connected incorrectly	Disconnect the stator from the valve and the cable and measure the resistance of the windings using an ordinary tester. The resistance of both should be around 36 ohms. Otherwise replace the stator. Finally, check the electrical connections of the cable to the driver.
	Valve stuck open	Check if the superheating is always low (<2 °C) with the valve position permanently at 0 steps. If so, set the valve to manual control and close it completely. If the superheat is always low, check the electrical connections and/or replace the valve.
	The "valve opening at start-up" parameter is too high on many showcases in which the control set point is often reached (for multiplexed showcases only)	Decrease the value of the "Valve opening at start-up" parameter on all the utilities, making sure that there are no repercussions on the control temperature.
Liquid returns to the compressor only after defrosting (for multiplexed showcases only)	The pause in control after defrosting is too short (for MasterCase, MasterCase 2 and mpXPRO only)	Increase the value of the "valve control delay after defrosting" parameter.
	The superheat temperature measured by the driver after defrosting and before reaching operating conditions is very low for a few minutes	Check that the LowSH threshold is greater than the superheat value measured and that the corresponding protection is activated (integral time > 0sec). If necessary, decrease the value of the integral time.
	The superheat temperature measured by the driver does not reach low values, but there is still return of liquid to the compressor rack	Set more reactive parameters to bring forward the closing of the valve: increase the proportional factor to 30, increase the integral time to 250 sec and increase the derivative time to 10 sec.
	Many showcases defrosting at the same time	Stagger the start defrost times. If this is not possible, if the conditions in the previous two points are not present, increase the superheat set point and the LowSH thresholds by at least 2 °C on the showcases involved.
	The valve is significantly oversized	Replace the valve with a smaller equivalent.
Liquid returns to the compressor only when starting the controller (after being OFF)	The "valve opening at start-up" parameter is set too high	Check the calculation in reference to the ratio between the rated cooling capacity of the evaporator and the capacity of the valve; if necessary, lower the value.
The superheat value swings around the set point with an amplitude greater than 4°C	The condensing pressure swings	Check the controller condenser settings, giving the parameters "blander" values (e.g. increase the proportional band or increase the integral time). Note: the required stability involves a variation within +/- 0.5 bars. If this is not effective or the settings cannot be changed, adopt electronic valve control parameters for perturbed systems (see paragraph 8.3)
	The superheat swings even with the valve set in manual control (in the position corresponding to the average of the working values)	Check for the causes of the swings (e.g. low refrigerant charge) and resolve where possible. If not possible, adopt electronic valve control parameters for perturbed systems (see paragraph 8.3).
	The superheat does NOT swing with the valve set in manual control (in the position corresponding to the average of the working values)	As a first approach, decrease (by 30 to 50 %) the proportional factor. Subsequently try increasing the integral time by the same percentage. In any case, adopt parameter settings recommended for stable systems.
	The superheat set point is too low	Increase the superheat set point and check that the swings are reduced or disappear. Initially set 13 °C, then gradually reduce the set point, making sure the system does not start swinging again and that the unit temperature reaches the control set point.

PROBLEM	CAUSE	SOLUTION
In the start-up phase with high evaporator temperatures, the evaporation pressure is high	MOP protection disabled or ineffective	Activate the MOP protection by setting the threshold to the required saturated evaporation temperature (high evaporation temperature limit for the compressors) and setting the MOP integral time to a value above 0 (recommended 4 seconds). To make the protection more reactive, decrease the MOP integral time.
	Refrigerant charge excessive for the system or extreme transitory conditions at start-up (for showcases only).	Apply a "soft start" technique, activating the utilities one at a time or in small groups. If this is not possible, decrease the values of the MOP thresholds on all the utilities.
In the start-up phase the low pressure protection is activated (only for units with compressor on board)	The "Valve opening at start-up" parameter is set too low	Check the calculation in reference to the ratio between the rated cooling capacity of the evaporator and the capacity of the valve; if necessary lower the value.
	The driver in pLAN or tLAN configuration does not start control and the valve remains closed	Check the pLAN / tLAN connections. Check that the pCO application connected to the driver (where featured) correctly manages the driver start signal. Check that the driver is NOT in stand-alone mode.
	The driver in stand-alone configuration does not start control and the valve remains closed	Check the connection of the digital input. Check that when the control signal is sent that the input is closed correctly. Check that the driver is in stand-alone mode.
	LOP protection disabled	Set a LOP integral time greater than 0 sec.
	LOP protection ineffective	Make sure that the LOP protection threshold is at the required saturated evaporation temperature (between the rated evaporation temperature of the unit and the corresponding temperature at the calibration of the low pressure switch) and decrease the value of the LOP integral time.
	Solenoid blocked	Check that the solenoid opens correctly, check the electrical connections and the operation of the relay.
	Insufficient refrigerant	Check that there are no bubbles in the sight glass upstream of the expansion valve. Check that the subcooling is suitable (greater than 5 °C); otherwise charge the circuit.
	The valve is connected incorrectly (rotates in reverse) and is open	Check the movement of the valve by placing it in manual control and closing or opening it completely. One complete opening must bring a decrease in the superheat and vice-versa. If the movement is reversed, check the electrical connections.
	Stator broken or connected incorrectly	Disconnect the stator from the valve and the cable and measure the resistance of the windings using an ordinary tester. The resistance of both should be around 36 ohms. Otherwise replace the stator. Finally, check the electrical connections of the cable to the driver.
	The "Valve opening at start-up" parameter is set too low	Check the calculation in reference to the ratio between the rated cooling capacity of the evaporator and the capacity of the valve; if necessary lower the value.
The unit switches off due to low pressure during control (only for units with compressor on board)	LOP protection disabled	Set a LOP integral time greater than 0 sec.
	LOP protection ineffective	Make sure that the LOP protection threshold is at the required saturated evaporation temperature (between the rated evaporation temperature of the unit and the corresponding temperature at the calibration of the low pressure switch) and decrease the value of the LOP integral time.
	Solenoid blocked	Check that the solenoid opens correctly, check the electrical connections and the operation of the control relay.
	Insufficient refrigerant	Check that there are no bubbles of air in the liquid indicator upstream of the expansion valve. Check that the subcooling is suitable (greater than 5 °C); otherwise charge the circuit.
	The valve is significantly undersized	Replace the valve with a larger equivalent.
	Stator broken or connected incorrectly	Disconnect the stator from the valve and the cable and measure the resistance of the windings using an ordinary tester. The resistance of both should be around 36 ohms. Otherwise replace the stator. Finally, check the electrical connections of the cable to the driver (see paragraph 5.1).
	Valve stuck closed	Use manual control after start-up to completely open the valve. If the superheat remains high, check the electrical connections and/or replace the valve.
The showcase does not reach the set temperature, despite the valve being opened to the maximum (for multiplexed showcases only)	Solenoid blocked	Check that the solenoid opens correctly, check the electrical connections and the operation of the relay.
	Insufficient refrigerant	Check that there are no bubbles of air in the liquid indicator upstream of the expansion valve. Check that the subcooling is suitable (greater than 5 °C); otherwise charge the circuit.
	The valve is significantly undersized	Replace the valve with a larger equivalent.
	Stator broken or connected incorrectly	Disconnect the stator from the valve and the cable and measure the resistance of the windings using an ordinary tester. The resistance of both should be around 36 ohms. Otherwise replace the stator. Finally, check the electrical connections of the cable to the driver (see paragraph 5.1).
	Valve stuck closed	Use manual control after start-up to completely open the valve. If the superheat remains high, check the electrical connections and/or replace the valve.
The showcase does not reach the set temperature, and the position of the valve is always 0 (for multiplexed showcases only)	The driver in pLAN or tLAN configuration does not start control and the valve remains closed	Check the pLAN / tLAN connections. Check that the pCO application connected to the driver (where featured) correctly manages the driver start signal. Check that the driver is NOT in stand-alone mode.
	The driver in stand-alone configuration does not start control and the valve remains closed	Check the connection of the digital input. Check that when the control signal is sent that the input is closed correctly. Check that the driver is in stand-alone mode.

Tab. 10.a

11. TECHNICAL SPECIFICATIONS

Power supply (Lmax= 5 m)	<ul style="list-style-type: none"> • 24 Vac (+10/-15%) to be protected by external 2 A type T fuse. • 24 Vdc (+10/-15%) 50/60 Hz to be protected by external 2 A type T fuse. Use a dedicated class 2 transformer (max 100 VA). 	
Power input	16.2 W ; 35 VA	
Emergency power supply	22 Vdc +/-5%. (If the optional EVBAT00400 module is installed), Lmax=5 m	
Insulation between relay output and other outputs	reinforced; 6 mm in air, 8 mm on surface; 3750 V insulation	
Motor connection	4-wire shielded cable AWG 22, Lmax 10 m or AWG 14, Lmax= 50 m	
Digital input connection	Digital input to be activated from voltage-free contact or transistor to GND. Closing current 5 mA; Lmax< 30 m	
Probes (Lmax=10 m; with shielded cable less than 30 m)	S1	ratiometric pressure probe (0 to 5 V): <ul style="list-style-type: none"> • resolution 0.1 % fs; • measurement error: 2% fs maximum; 1% typical electronic pressure probe (4 to 20 mA): <ul style="list-style-type: none"> • resolution 0.5 % fs; • measurement error: 8% fs maximum; 7% typical remote electronic pressure probe (4 to 20mA). Maximum number of drivers connected=5 combined ratiometric pressure probe (0 to 5 V): <ul style="list-style-type: none"> • resolution 0.1 % fs; • measurement error: 2 % fs maximum; 1 % typical 4 to 20 mA input (max 24 mA): <ul style="list-style-type: none"> • resolution 0.5% fs; • measurement error: 8% fs maximum; 7% typical
	S2	low temperature NTC: <ul style="list-style-type: none"> • 10 kΩ at 25°C, -50T90 °C; • measurement error: 1°C in range -50T50 °C; 3°C in range +50T90 °C high temperature NTC: <ul style="list-style-type: none"> • 50 kΩ at 25°C, -40T150 °C; • measurement error: 1.5 °C in range -20T115 °C, 4 °C in range outside of -20T115 °C Combined NTC: <ul style="list-style-type: none"> • 10 kΩ at 25 °C, -40T120 °C; • measurement error: 1 °C in range -40T50 °C; 3°C in range +50T90 °C 0 to 10 V input (max 12 V): <ul style="list-style-type: none"> • resolution 0.1 % fs; • measurement error: 9% fs maximum; 8% typical
	S3	ratiometric pressure probe (0 to 5 V): <ul style="list-style-type: none"> • resolution 0.1 % fs; • measurement error: 2% fs maximum; 1% typical electronic pressure probe (4 to 20 mA): <ul style="list-style-type: none"> • resolution 0.5 % fs; • measurement error: 8% fs maximum; 7% typical remote electronic pressure probe (4 to 20mA). Maximum number of drivers connected=5 4 to 20 mA input (max 24 mA): <ul style="list-style-type: none"> • resolution 0.5% fs; • measurement error: 8% fs maximum; 7% typical combined ratiometric pressure probe (0 to 5 V): <ul style="list-style-type: none"> • resolution 0.1 % fs, • measurement error: 2 % fs maximum; 1 % typical
	S4	low temperature NTC: <ul style="list-style-type: none"> • 10 kΩ at 25°C, -50T105°C; • measurement error: 1°C in range -50T50 °C; 3°C in range 50T90°C high temperature NTC: <ul style="list-style-type: none"> • 50 kΩ at 25°C, -40T150°C; • measurement error: 1.5°C in range -20T115°C 4°C in range outside of -20T115°C Combined NTC: <ul style="list-style-type: none"> • 10 kΩ at 25°C, -40T120°C; • measurement error 1°C in range -40T50°C; 3°C in range +50T90°C
	Relay output	normally open contact; 5 A, 250 Vac resistive load; 2 A, 250 Vac inductive load (PF=0.4); Lmax=50 m; UL: 250 Vac, 5 A resistive, 1A FLA, 6A LRA, pilot duty D300. 30000 cycles VDE: 1(1)A PF=0.6
	Power supply to active probes (V _{REF})	+5 Vdc ±2% o 12 Vdc ±10% depending on type of probe set
	RS485 serial connection	Lmax=1000 m, shielded cable
	tLAN connection	Lmax=30 m, shielded cable
	pLAN connection	Lmax=500 m, shielded cable
	Assembly	DIN rail
	Connectors	plug-in, cable size 0.5 to 2.5 mm ² (12 to 20 AWG)
	Dimensions	LxHxW= 70x110x60
	Operating conditions	-25T60°C (don't use EVDIS* under -20°C); <90% RH non-condensing
	Storage conditions	-35T60°C (don't store EVDIS* under -30°C), humidity 90% RH non-condensing
	Index of protector	IP20
	Environmental pollution	2 (normal)
Resistance to heat and fire	Category D	
Immunity against voltage surges	Category 1	
Rated impulse voltage	2500V	
Type of relay action	1C microswitching	
Insulation class	2	
Software class and structure	A	
Conformity	Electrical safety: EN 60730-1, EN 61010-1, UL873, VDE 0631-1 Electromagnetic compatibility: EN 61000-6-1, EN 61000-6-2, EN 61000-6-3, EN 61000-6-4; EN61000-3-2, EN55014-1, EN55014-2, EN61000-3-3.	

Tab. 11.a

12. APPENDIX: VPM (VISUAL PARAMETER MANAGER)

12.1 Installation

On the <http://ksa.carel.com> website, under the Parametric Controller Software section, select Visual Parameter Manager.

A window opens, allowing 3 files to be downloaded:

1. VPM_CD.zip: for burning to a CD;
2. Upgrade setup;
3. Full setup: the complete program.

For first installations, select Full setup, for upgrades select Upgrade setup. The program is installed automatically, by running setup.exe.

Note: if deciding to perform the complete installation (Full setup), first uninstall any previous versions of VPM.

12.2 Programming (VPM)

When opening the program, the user needs to choose the device being configured: EVD evolution. The Home page then opens, with the choice to create a new project or open an existing project. Choose new project and enter the password, which when accessed the first time can be set by the user.

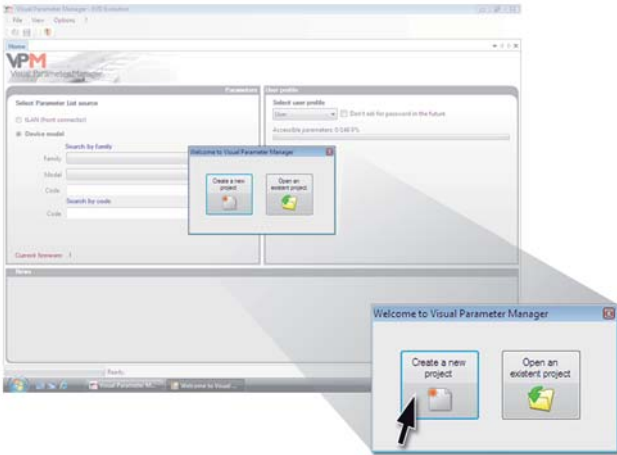

Fig. 12.a

Then the user can choose to:

1. directly access the list of parameters for the EVD evolution twin saved to EEPROM: select "tLAN";

This is done in real time (ONLINE mode), at the top right set the network address 198 and choose the guided recognition procedure for the USB communication port. Enter at the Service or Manufacturer level.

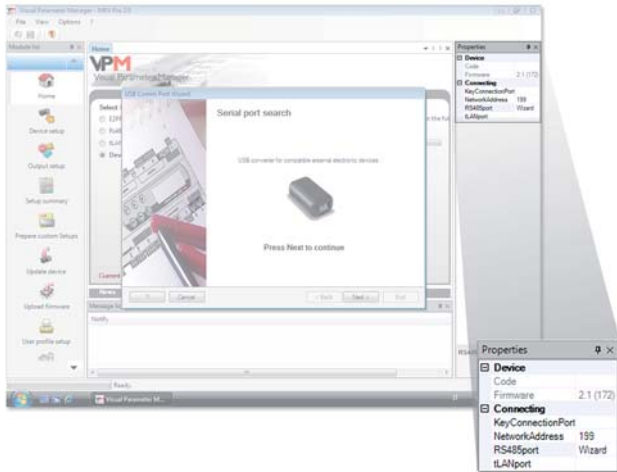

Fig. 12.b

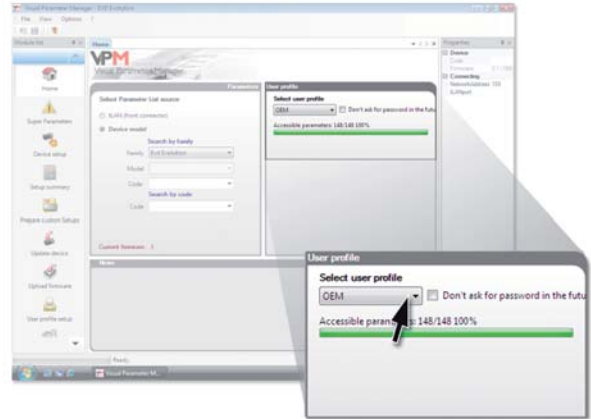

Fig. 12.c

2. select the model from the range and create a new project or choose an existing project: select "Device model".

A new project can be created, making the changes and then connecting later on to transfer the configuration (OFFLINE mode). Enter at the Service or Manufacturer level.

- select Device model and enter the corresponding code

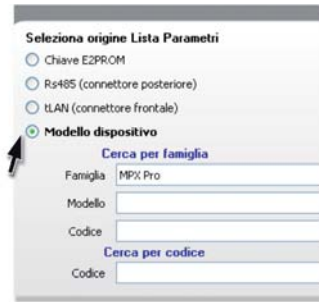

Fig. 12.d

- go to Configure device: the list of parameters will be displayed, allowing the changes relating to the application to be made.

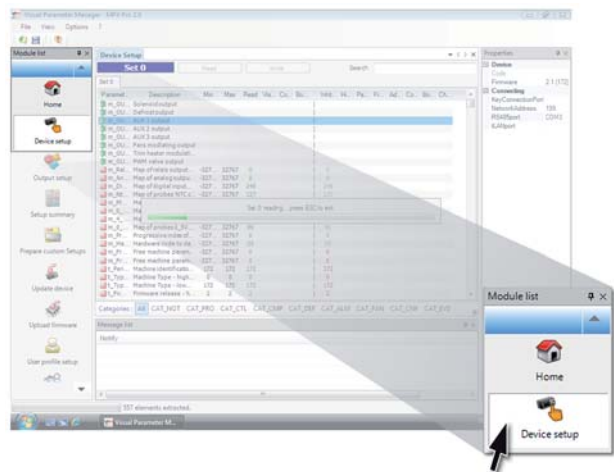

Fig. 12.e

At the end of configuration, to save the project choose the following command, used to save the configuration as a file with the .hex extension.

File -> Save parameter list.

To transfer the parameters to the controller, choose the "Write" command. During the write procedure, the 2 LEDs on the converter will flash.

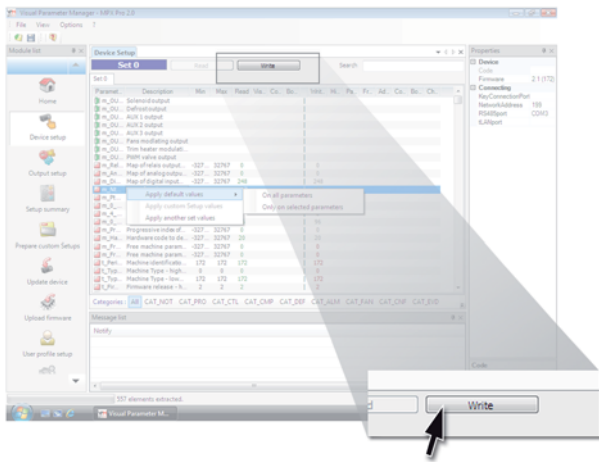



Fig. 12.f

 **Note:** the program On-line help can be accessed by pressing F1.

12.3 Copying the setup

On the Configure device page, once the new project has been created, to transfer the list of configuration parameters to another controller:

- read the list of parameters from the source controller with the “Read” command;
- remove the connector from the service serial port;
- connect the connector to the service port on the destination controller;
- write the list of parameters to the destination controller with the “Write” command.

 **Important:** the parameters can only be copied between controllers with the same code. Different firmware versions may cause compatibility problems.

12.4 Setting the default parameters

When the program opens:

- select the model from the range and load the associated list of parameters;
- go to “Configure device”: the list of parameters will be shown, with the default settings.
- connect the connector to the service serial port on the destination controller;
- select “Write”. During the write procedure, the LEDs on the converter will flash.

The controller parameters will now have the default settings.

12.5 Updating the controller and display firmware

The controller and display firmware must be updated using the VPM program on a computer and the USB/tLAN converter, which is connected to the device being programmed (see paragraph 2.7 for the connection diagram). The firmware can be downloaded from <http://ksa.carel.com>. See the VPM On-line help.

CAREL

CAREL INDUSTRIES HQs
Via dell'Industria, 11 - 35020 Brugine - Padova (Italy)
Tel. (+39) 049.9716611 - Fax (+39) 049.9716600
e-mail: carel@carel.com - www.carel.com

Agenzia / Agency: